



IBRA
SHOWERS

BOX DOCCIA
SHOWER ENCLOSURES
PAROIS DE DOUCHE

ICON
> 8 mm

ICON



Scopri le caratteristiche tecniche
Discover the technical features
Découvrez les caractéristiques techniques



ICON

Caratteristiche / features / caractéristiques

- | | | |
|--|---|--|
| <ul style="list-style-type: none"> > H 200 cm > Chiusura a calamita inserita su profilo in alluminio > Profili gocciolatoi in PVC trasparente antigoccia > Profilo inferiore di contenimento acqua > Porta battente sollevabile > Porta battente con apertura in/out > Braccetti di sostegno in alluminio accorciabili in opera > Profili verticali dotati di tappi di chiusura trasparenti > Possibilità di fuori misura > Sistema di sgancio della porta scorrevole in opera > Regolazione del sistema di scorrimento > Regolazione del profilo a pavimento per piatti doccia non perfettamente orizzontali > Montaggio rapido | <ul style="list-style-type: none"> > H 200 cm > Magnetic closing system inserted in the aluminium seal > Drip gaskets in transparent PVC anti-mould > Water containment profil > Hinged door with lift system > Hinged door with in/out opening > Aluminium stabilizing bar to be cut during installation > Transparent upper covers for the adjustment profil > Out of standard on request > Quick release system > Adjustable sliding system > Possibility to adjust the profile if the shower tray is not perfectly aligned > Easy to assemble | <ul style="list-style-type: none"> > H 200 cm > Fermeture magnetique inserée dans le profil en aluminium > Profils en PVC contre l'éclaboussement > Profils inférieur pour le confinement de l'eau > Porte battente relevable > Porte battente avec ouverture in/out > Soutiens en aluminium à couper en cours de réalisation > Profils verticaux avec bouchons de fermeture transparents > Hors standard sur demande > Décrochage rapide de la porte coulissante > Régulation des coulisses > Régulation du profil inférieur pour recevoir non horizontal > Assemblage rapide |
|--|---|--|

Vetri / glasses / verres



- | | | | | | | | |
|-------------------|---------------------|----------------|--------------|--------------|----------------|-------------------|---|
| 00
Trasparente | GE
Grigio Europa | SA
Satinato | BZ
Bronzo | X1
Nuvola | TL
Timeless | EC
Extrachiaro | X2-X3-X4-X5
Serigrafie
(v. pag. 371)
Serigraphies
(see page 371)
Sérigraphies
(voir page 371) |
|-------------------|---------------------|----------------|--------------|--------------|----------------|-------------------|---|

Profili / profiles / p ofil

BRILL:



B
Brill

SPECIAL:



N
Nero



Z
Bronzo



O
Oro spazzolato



C
Rame
(escluso scorrevole)
(not available for sliding)
(non disponible pour coulissant)



R
Rodio lucido



X
Inox spazzolato

ICON - MANIGLIE



BEAK

maniglia di serie
as standard
de série

- > Fissata sul profilo in alluminio
- > Fixed to the aluminium profil
- > Fixée au profil en aluminium



TI

alternativa (specificare nell'ordine)
optional (to specify in the order)
alternative (indiquer dans la commande)

- > Fissata sul vetro
- > Fixed to the glass
- > Fixée au verre

- > Sovraprezzo:
- > Surcharge:
- > Supplément:

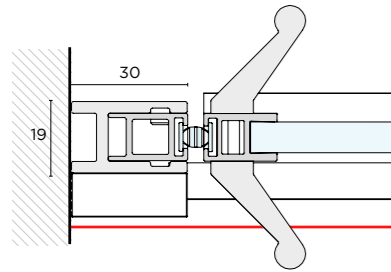

Battuta della porta battente in nicchia
 Abutment of the hinged door in a niche
 Butée de la porte battante en niche

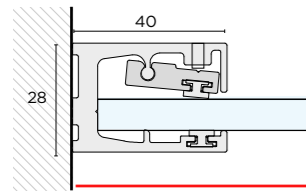

Fissaggio a muro
 Wall mounting
 Fixation au mur

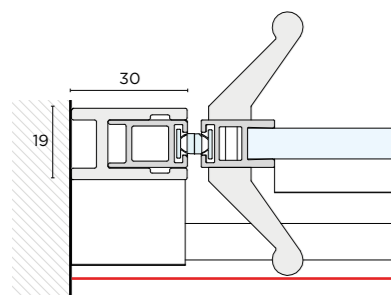

Battuta della porta scorrevole in nicchia
 Abutment of the sliding door in a niche
 Butée de la porte coulissante en niche

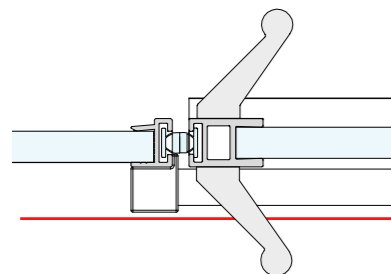

Battuta con fisso in linea
 Abutment with an aligned fixed panel
 Butée avec profile fixe aligné

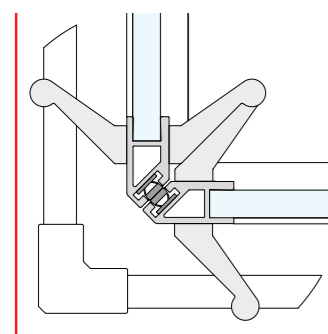

Angolo con porte scorrevoli
 Corner with sliding sliding doors
 Angle avec portes coulissantes

Configurazioni / configurations / configurations

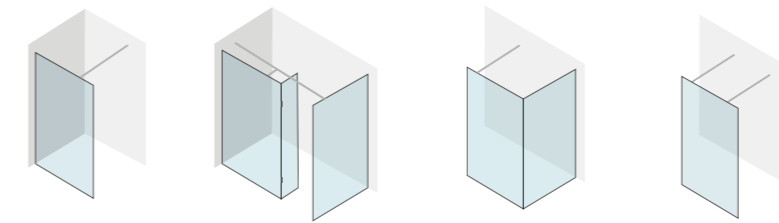

A	B	C	D
ANGOLO > Walk-in	ANGOLO > Walk-in con fisso laterale	PARETE > Angolo walk-in	PARETE > Walk-in
Walk-in corner	Walk-in corner with fixed panel	Walk-in wall	Walk-in wall
Walk-in en coin	Walk-in sur coin avec paroi fixe laterale	Walk-in en coin avec paroi	Walk-in à paroi

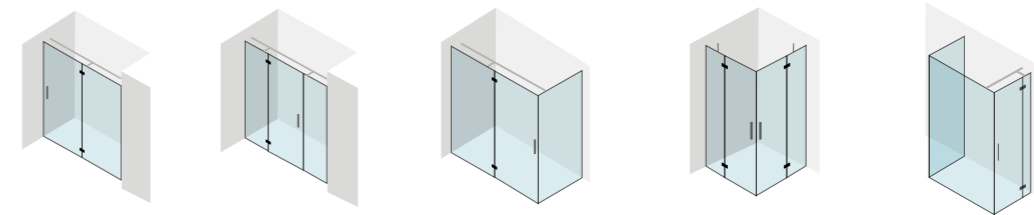

NICCHIA > Battente	NICCHIA > Battente con porta centrale	ANGOLO > Battente 1 porta + fisso laterale	ANGOLO > Battente 2 porte	PARETE > 3 lati
Hinged door with in-line fixed panel	Hinged door with 2 in-line fixed panels	Hinged door with in-line fixed panel + fixed side panel	2 hinged doors with in-line fixed panels	Hinged door with 2 fixed panels
Porte battante avec paroi fixe alignée	Porte battante avec 2 parois fixes alignées	Porte battante avec paroi fixe alignée + côté fixe	2 portes battantes avec parois alignées	Porte battante avec côté fixes

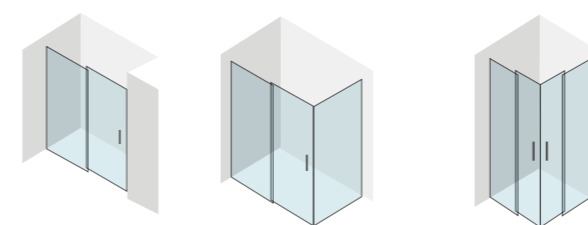

NICCHIA > Scorrevole	ANGOLO > Scorrevole 1 porta + fisso laterale	ANGOLO > Scorrevole 2 porte
1 sliding door	1 sliding door + fixed panel	2 sliding doors
Porte coulissante	Porte coulissante + côté fixe	2 portes coulissantes

ICON: **WALK-IN**

LEGENDA KEY / LÉGENDE

F fi so / fi ed panel / côté fi e
L lato / lateral fi ed panel / côté fi e latéral
A apertura / opening / entrée
P porta / door / porte

ICON **WALK-IN**

Di serie:
 Standard:
 De série:

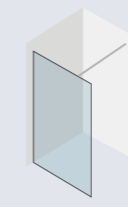

A

ANGOLO > Walk-in

Walk-in
 corner

Walk-in
 en coin

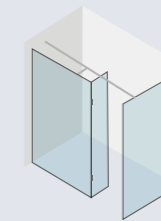

B

ANGOLO > Walk-in con fisso laterale

Walk-in corner
 with fixed panel

Walk-in sur coin avec
 paroi fixe laterale



C

PARETE > Angolo walk-in

Walk-in
 wall

Walk-in
 en coin
 avec paroi



D

PARETE > Walk-in

Walk-in
 wall

Walk-in
 à paroi

A richiesta
 (contattare ufficio tecnico):
 On request
 (to be verified with technical
 department):
 Sur demande
 (vérifier avec le département
 technique):

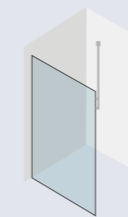

> Walk-in a soffitto

Walk-in
 fixed to the ceiling

Walk-in
 à fixer au plafond

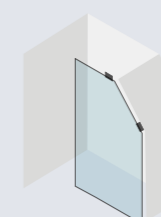

> Walk-in sottotetto

Walk-in for
 sloped ceiling

Walk-in pour
 plafond incliné

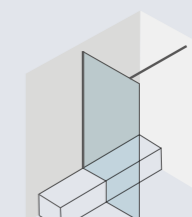

> Walk-in sagomato

Walk-in
 shaped panel

Walk-in
 paroi façonnée

Dettagli / details / détails



Braccetto dritto a parete:
 Un elemento estetico e funzionale che
 sostiene il vetro.

Straight wall-mounted support arm:
 A functional and aesthetic feature that
 supports the glass.

Bras droit à paroi:
 Un élément esthétique et fonctionnel à
 soutien du verre.



Braccetto a T:
 Una barra di sostegno per vetri di grandi
 dimensioni.

T-shaped support arm:
 A support bar for large glass panels.

Bras en forme de T:
 Une barre de soutien pour verre de
 grandes dimensions.



Aletta girevole:
 Accessorio che può essere aggiunto dopo
 l'installazione.

Deflector:
 This accessory can be added after
 installation.

Ailette:
 Accessoire qui peut être ajouté après
 installation.

01.

**Walk-in
ad angolo**
nero + vetro trasparente

*Walk-in
corner*
in nero + trasparente glass

*Walk-in
en coin*
en nero + verre transparente



Piatto doccia:
Aureo Laminam Calce Antracite
L 140 x P 80 cm

Shower tray:
Aureo Laminam Calce Antracite
W 140 x D 80 cm

Receveur:
Aureo Laminam Calce Antracite
L 140 x P 80 cm



Pinza ferma vetro
dal design minimale

**Clip for
glas panel**
in minimal design

**Pince pour paroi
en verre**
en design minimal

**Vetro in appoggio
sul piatto**
per facilitare la
pulizia

**Glass panel directly
mounted into the tray**
for an easier cleaning

**Paroi apposée sur
le receveur**
pour un nettoyage
plus simple



02.

**Walk-in
a parete**
oro + vetro Nuvola

**Walk-in
wall**
in oro + Nuvola glass

**Walk-in
à paroi**
en oro + verre Nuvola



Piatto doccia:
Elle bianco L 140 x P 80 cm

Shower tray:
Elle bianco W 140 x D 80 cm

Receveur:
Elle bianco L 140 x P 80 cm

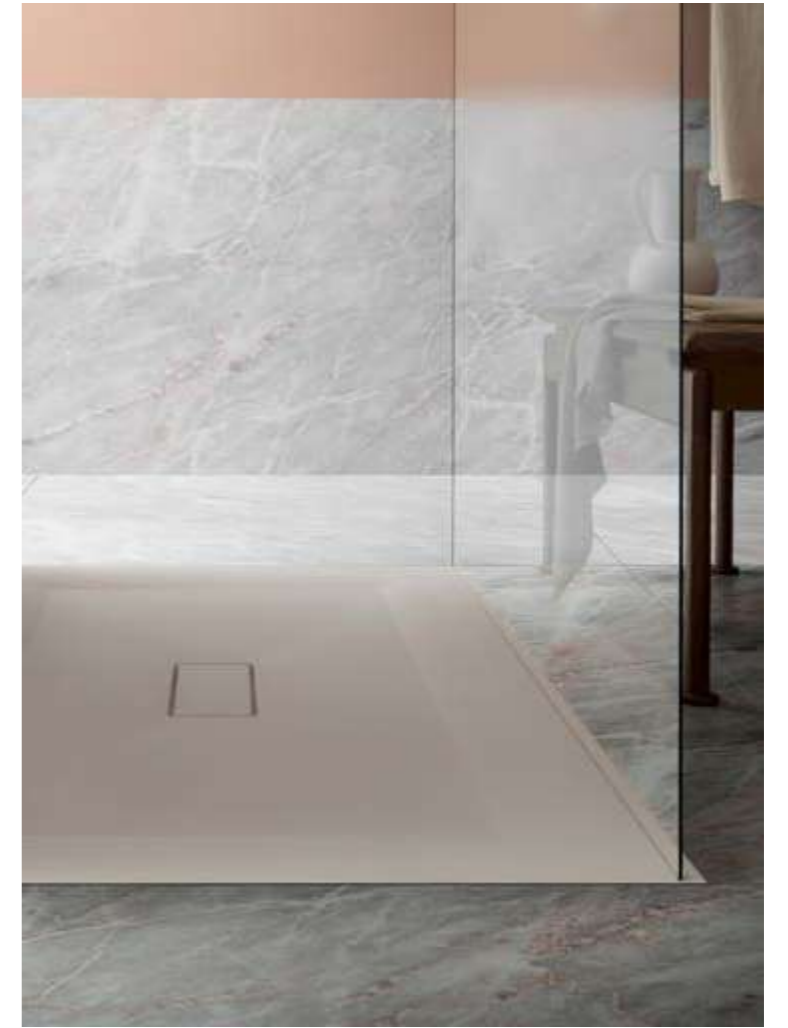

03.

**Walk-in ad angolo
con fisso laterale + aletta girevole**
inox spazzolato + vetro trasparente

**Walk-in corner
with fixed panel + deflector**
in inox spazzolato + trasparente glass

**Walk-in sur coin
avec paroi fixe latéral + ailette**
en inox spazzolato + verre transparente

Piatto doccia:
Linear bianco L 180 x P 80 cm

Shower tray:
Linear bianco W 180 x D 80 cm

Receveur:
Linear bianco L 180 x P 80 cm





**Braccetto a "T"
e aletta girevole**
dal design
minimale

**"T-shaped" support arm
and swivel deflector**
in minimal design

**Bras en forme de "T"
et ailette pivotante**
en un design
minimal



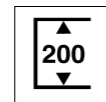

Altezza 200 cm
Height 200 cm
Hauteur 200 cm

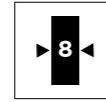

Vetro sp. 8 mm
Glass th. 8 mm
Verre ép. 8 mm



Fuori misura:
altezza max 220 cm / larghezza max 160 cm
Out of standard:
height max. 220 cm / width max. 160 cm
Sur demande:
hauteur max. 220 cm / largeur max. 160 cm

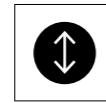

Reversibile
Reversible
Réversible



Braccetto accorciabile in opera compreso nel prezzo
Stabilizing bar to be cutted during installation included
Barre de soutien à couper en cours de réalisation comprise dans le prix.

Configurazioni:
Configurations:
Configurations:

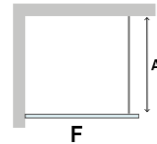

VERSIONE SX
Left
Gauche

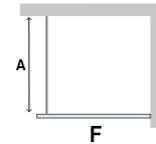

VERSIONE DX
Right
Droite

Fuori Misura:
Out of standard:
Sur mesure:



+ 30 %

(richiedere fattibilità)
(ask for feasibility)
(vérifier la faisabilité avec le service technique)

Trattamento anticalcare:
Glass treatment:
Traitement verre:



+ 80

Lato
Side
Verre

Vetro Extralight / Timeless:
Extralight/Timeless glass:
Verre Extralight/Timeless:



+ 40 %

Vetro con serigrafie:
Serigraphies (see page 371):
Sérigraphies (voir page 371):



+ 25 %

maggiorazione dal TRASPARENTE
increase on the TRASPARENTE price
à appliquer sur le prix du TRASPARENTE

Vetro Nuvola:
Nuvola glass (see page 371):
Verre Nuvola (voir page 371):



+ 7 / cm

Profili speciali:
Special profile :
Profils spéciaux

- > BRONZO
- > ORO SPAZZOLATO
- > RAME
- > RODIO LUCIDO
- > INOX SPAZZOLATO

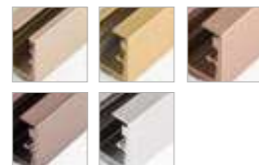

Lato
Side
Verre

Aletta
Deflector
Ailette



F - FISSO / FIXED PANEL / CÔTÉ FIXE

ART. ITEM ART.	ESTENSIBILITÀ EXTENSIBILITY EXTENSIBILITÉ	PIATTO SHOWER TRAY RECEVEUR	PROFILO PROFILE PROFIL	VETRO / GLASS / VERRE TRASPARENTE	VETRO / GLASS / VERRE GRIGIO EUROPA SATIN - BRONZO
D8WA110	77,5 - 79,5	80	BRILL - NERO		
D8WA115	82,5 - 84,5	85	BRILL - NERO		
D8WA120	87,5 - 89,5	90	BRILL - NERO		
D8WA125	92,5 - 94,5	95	BRILL - NERO		
D8WA130	97,5 - 99,5	100	BRILL - NERO		
D8WA135	102,5 - 104,5	105	BRILL - NERO		
D8WA140	107,5 - 109,5	110	BRILL - NERO		
D8WA145	112,5 - 114,5	115	BRILL - NERO		
D8WA150	117,5 - 119,5	120	BRILL - NERO		
D8WA155	122,5 - 124,5	125	BRILL - NERO		
D8WA160	127,5 - 129,5	130	BRILL - NERO		
D8WA165	132,5 - 134,5	135	BRILL - NERO		
D8WA170	137,5 - 139,5	140	BRILL - NERO		
D8WA175	142,5 - 144,5	145	BRILL - NERO		
D8WA180	147,5 - 149,5	150	BRILL - NERO		
D8WA185	152,5 - 154,5	155	BRILL - NERO		
D8WA190	157,5 - 159,5	160	BRILL - NERO		

OPTIONAL - GIREVOLE / DEFLECTOR / AILETTE

ART. ITEM ART.	LUNGHEZZA WIDTH LONGUEUR	PIATTO SHOWER TRAY RECEVEUR	CERNIERE HINGES CHARNIÈRES	VETRO / GLASS / VERRE TRASPARENTE	VETRO / GLASS / VERRE GRIGIO EUROPA SATIN - BRONZO
D8AG100	30	-	BRILL - NERO		

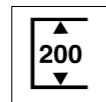

Altezza 200 cm
Height 200 cm
Hauteur 200 cm

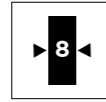

Vetro sp. 8 mm
Glass th. 8 mm
Verre ép. 8 mm



Fuori misura:
altezza max 220 cm / larghezza max 160 cm
Out of standard:
height max. 220 cm / width max. 160 cm
Sur demande:
hauteur max. 220 cm / largeur max. 160 cm

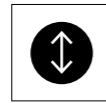

Reversibile
Reversible
Réversible



Braccetto accorciabile in opera compreso nel prezzo
Stabilizing bar to be cutted during installation included
Barre de soutien à couper en cours de réalisation comprise dans le prix.

Configurazioni:
Configurations:
Configurations:

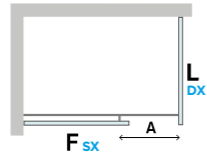

VERSIONE SX
Left
Gauche

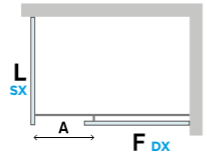

VERSIONE DX
Right
Droite

Fuori Misura:
Out of standard:
Sur mesure:



+ 30 %

(richiedere fattibilità)
(ask for feasibility)
(vérifier la faisabilité avec le service technique)

Trattamento anticalcare:
Glass treatment:
Traitement verre:



+ 80

Lato
Side
Verre

Vetro Extralight / Timeless:
Extralight/Timeless glass:
Verre Extralight/Timeless:



+ 40 %

Vetro con serigrafie:
Serigraphies (see page 371):
Sérigraphies (voir page 371):



+ 25 %

maggiorazione dal TRASPARENTE
increase on the TRASPARENTE price
à appliquer sur le prix du TRASPARENTE

Vetro Nuvola:
Nuvola glass (see page 371):
Verre Nuvola (voir page 371):



+ 7 / cm

Profili speciali:
Special profile :
Profils spéciaux

- > BRONZO
- > ORO SPAZZOLATO
- > RAME
- > RODIO LUCIDO
- > INOX SPAZZOLATO



Lato
Side
Verre

Aletta
Deflector
Ailette



F - FISSO / FIXED PANEL / CÔTÉ FIXE

ART. ITEM ART.	ESTENSIBILITÀ EXTENSIBILITY EXTENSIBILITÉ	PIATTO SHOWER TRAY RECEVEUR	PROFILO PROFILE PROFIL	VETRO / GLASS / VERRE TRASPARENTE	VETRO / GLASS / VERRE GRIGIO EUROPA SATIN - BRONZO
D8WA300	67,5 - 69,5	-	BRILL - NERO		
D8WA305	72,5 - 74,5	-	BRILL - NERO		
D8WA310	77,5 - 79,5	-	BRILL - NERO		
D8WA315	82,5 - 84,5	-	BRILL - NERO		
D8WA320	87,5 - 89,5	-	BRILL - NERO		
D8WA325	92,5 - 94,5	-	BRILL - NERO		
D8WA330	97,5 - 99,5	-	BRILL - NERO		
D8WA335	102,5 - 104,5	-	BRILL - NERO		
D8WA340	107,5 - 109,5	-	BRILL - NERO		
D8WA345	112,5 - 114,5	-	BRILL - NERO		
D8WA350	117,5 - 119,5	-	BRILL - NERO		



L - FISSO / FIXED PANEL / CÔTÉ FIXE

ART. ITEM ART.	ESTENSIBILITÀ EXTENSIBILITY EXTENSIBILITÉ	PIATTO SHOWER TRAY RECEVEUR	PROFILO PROFILE PROFIL	VETRO / GLASS / VERRE TRASPARENTE	VETRO / GLASS / VERRE GRIGIO EUROPA SATIN - BRONZO
D8WA355	67,5 - 69,5	70	BRILL - NERO		
D8WA360	72,5 - 74,5	75	BRILL - NERO		
D8WA365	77,5 - 79,5	80	BRILL - NERO		
D8WA370	82,5 - 84,5	85	BRILL - NERO		
D8WA375	87,5 - 89,5	90	BRILL - NERO		
D8WA380	92,5 - 94,5	95	BRILL - NERO		
D8WA385	97,5 - 99,5	100	BRILL - NERO		

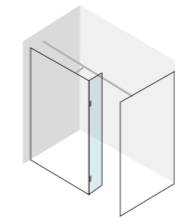

OPTIONAL - GIREVOLE / DEFLECTOR / AILETTE

ART. ITEM ART.	LUNGHEZZA WIDTH LONGUEUR	PIATTO SHOWER TRAY RECEVEUR	CERNIERE HINGES CHARNIÈRES	VETRO / GLASS / VERRE TRASPARENTE	VETRO / GLASS / VERRE GRIGIO EUROPA SATIN - BRONZO
D8AG100	30	-	BRILL - NERO		

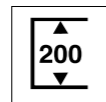

Altezza 200 cm
Height 200 cm
Hauteur 200 cm

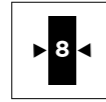

Vetro sp. 8 mm
Glass th. 8 mm
Verre ép. 8 mm



Fuori misura:
altezza max 220 cm / larghezza max 160 cm
Out of standard:
height max. 220 cm / width max. 160 cm
Sur demande:
hauteur max. 220 cm / largeur max. 160 cm

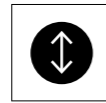

Reversibile
Reversible
Réversible



Braccetto accorciabile in opera compreso nel prezzo
Stabilizing bar to be cutted during installation included
Barre de soutien à couper en cours de réalisation comprise dans le prix

Configurazioni:
Configurations:
Configurations:

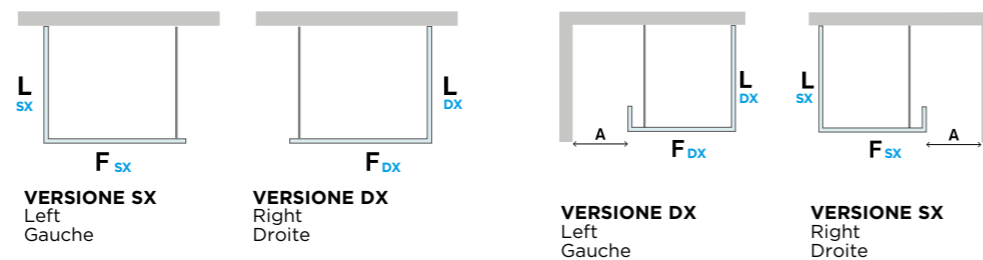

Fuori Misura:
Out of standard:
Sur mesure:

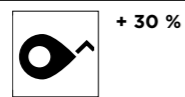

+ 30 %

(richiedere fattibilità)
(ask for feasibility)
(vérifier la faisabilité avec le service technique)

Trattamento anticalcare:
Glass treatment:
Traitement verre:



+ 80

Lato
Side
Verre

Vetro Extralight / Timeless:
Extralight/Timeless glass:
Verre Extralight/Timeless:



+ 40 %

Vetro con serigrafie:
Serigraphies (see page 371):
Sérigraphies (voir page 371):



+ 25 %

maggiorazione dal TRASPARENTE
increase on the TRASPARENTE price
à appliquer sur le prix du TRASPARENTE

Vetro Nuvola:
Nuvola glass (see page 371):
Verre Nuvola (voir page 371):



+ 7 / cm

Profili speciali:
Special profile :
Profils speciaux

- > BRONZO
- > ORO SPAZZOLATO
- > RAME
- > RODIO LUCIDO
- > INOX SPAZZOLATO



Lato
Side
Verre

Aletta
Deflector
Ailette



ATTENZIONE
Specificare il verso al momento dell'ordine.

ATTENTION
Indicate the side in the order.

ATTENTION
Indiquer le vers dans la commande.

F - FISSO / FIXED PANEL / CÔTÉ FIXE

ART. ITEM ART.	L. W. L.	PIATTO SHOWER TRAY RECEVEUR	PROFILO PROFILE PROFIL	VETRO / GLASS / VERRE TRASPARENTE	VETRO / GLASS / VERRE GRIGIO EUROPA SATIN - BRONZO
D8WP100	69	-	BRILL - NERO		
D8WP105	74	-	BRILL - NERO		
D8WP110	79	-	BRILL - NERO		
D8WP115	84	-	BRILL - NERO		
D8WP120	89	-	BRILL - NERO		
D8WP125	94	-	BRILL - NERO		
D8WP130	99	-	BRILL - NERO		
D8WP135	104	-	BRILL - NERO		
D8WP140	109	-	BRILL - NERO		
D8WP145	114	-	BRILL - NERO		
D8WP150	119	-	BRILL - NERO		

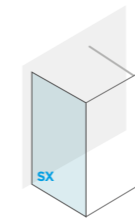

ATTENZIONE
Specificare il verso al momento dell'ordine.

ATTENTION
Indicate the side in the order.

ATTENTION
Indiquer le vers dans la commande.

L - FISSO / FIXED PANEL / CÔTÉ FIXE

ART. ITEM ART.	L. W. L.	PIATTO SHOWER TRAY RECEVEUR	PROFILO PROFILE PROFIL	VETRO / GLASS / VERRE TRASPARENTE	VETRO / GLASS / VERRE GRIGIO EUROPA SATIN - BRONZO
D8WP155	67,5 - 69,5	70	BRILL - NERO		
D8WP160	72,5 - 74,5	75	BRILL - NERO		
D8WP165	77,5 - 79,5	80	BRILL - NERO		
D8WP170	82,5 - 84,5	85	BRILL - NERO		
D8WP175	87,5 - 89,5	90	BRILL - NERO		
D8WP180	92,5 - 94,5	95	BRILL - NERO		
D8WP185	97,5 - 99,5	100	BRILL - NERO		

OPTIONAL - GIREVOLE / DEFLECTOR / AILETTE

ART. ITEM ART.	LUNGHEZZA WIDTH LONGUEUR	PIATTO SHOWER TRAY RECEVEUR	CERNIERE HINGES CHARNIÈRES	VETRO / GLASS / VERRE TRASPARENTE	VETRO / GLASS / VERRE GRIGIO EUROPA SATIN - BRONZO
D8AG100	30	-	BRILL - NERO		

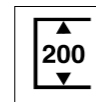

Altezza 200 cm
Height 200 cm
Hauteur 200 cm

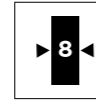

Vetro sp. 8 mm
Glass th. 8 mm
Verre ép. 8 mm



Fuori misura:
altezza max 220 cm / larghezza max 160 cm
Out of standard:
height max. 220 cm / width max. 160 cm
Sur demande:
hauteur max. 220 cm / largeur max. 160 cm



Reversibile
Reversible
Réversible



Braccetti accorciabili in opera compresi nel prezzo
Stabilizing bars to be cutted during installation included
Barres de soutien à couper en cours de réalisation comprises dans le prix.

Configurazioni:
Configurations:
Configurations:

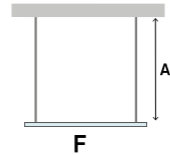

VERSIONE SX / DX
Left / Right
Gauche / Droite

Fuori Misura:
Out of standard:
Sur mesure:



+ 30 %

(richiedere fattibilità)
(ask for feasibility)
(vérifier la faisabilité avec le service technique)

Trattamento anticalcare:
Glass treatment:
Traitement verre:



+ 80

Lato
Side
Verre

Vetro Extralight / Timeless:
Extralight/Timeless glass:
Verre Extralight/Timeless:



+ 40 %

Vetro con serigrafie:
Serigraphies (see page 371):
Sérigraphies (voir page 371):



+ 25 %

maggiorazione dal TRASPARENTE
increase on the TRASPARENTE price
à appliquer sur le prix du TRASPARENTE

Vetro Nuvola:
Nuvola glass (see page 371):
Verre Nuvola (voir page 371):



+ 7 / cm

Profili speciali:
Special profile :
Profils spéciaux

> BRONZO
> ORO SPAZZOLATO
> RAME
> RODIO LUCIDO
> INOX SPAZZOLATO



+ 200 **Lato**
Side
Verre

+ 100 **Aletta**
Deflector
Ailette

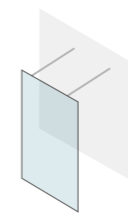

F - FISSO / FIXED PANEL / CÔTÉ FIXE

ART. ITEM ART.	L. W. L.	PIATTO SHOWER TRAY RECEVEUR	PROFILO PROFILE PROFIL	VETRO / GLASS / VERRE TRASPARENTE	VETRO / GLASS / VERRE GRIGIO EUROPA SATIN - BRONZO
D8WP195	67	-	BRILL - NERO		
D8WP200	72	-	BRILL - NERO		
D8WP205	77	-	BRILL - NERO		
D8WP210	82	-	BRILL - NERO		
D8WP215	87	-	BRILL - NERO		
D8WP220	92	-	BRILL - NERO		
D8WP225	97	-	BRILL - NERO		
D8WP230	102	-	BRILL - NERO		
D8WP235	107	-	BRILL - NERO		
D8WP240	112	-	BRILL - NERO		
D8WP245	117	-	BRILL - NERO		
D8WP250	122	-	BRILL - NERO		
D8WP255	127	-	BRILL - NERO		
D8WP260	132	-	BRILL - NERO		
D8WP265	137	-	BRILL - NERO		

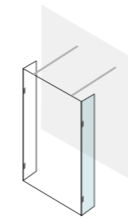

OPTIONAL - GIREVOLE / DEFLECTOR / AILETTE

ART. ITEM ART.	LUNGHEZZA WIDTH LONGUEUR	PIATTO SHOWER TRAY RECEVEUR	CERNIERE HINGES CHARNIÈRES	VETRO / GLASS / VERRE TRASPARENTE	VETRO / GLASS / VERRE GRIGIO EUROPA SATIN - BRONZO
D8AG100	30	-	BRILL - NERO		

ICON: **BATTENTE** **HINGED DOOR** **BATTANTE**

LEGENDA

KEY / LÉGENDE

F fi so / fi ed panel / côté fi e
L lato / lateral fi ed panel / côté fi e latéral
A apertura / opening / entrée
P porta / door / porte

ICON **BATTENTE**

Di serie:
Standard:

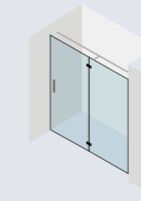

NICCHIA
> Battente

Hinged door with in-line fixed panel
 Porte battante avec paroi fixe alignée

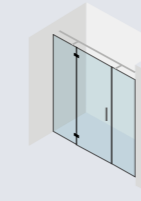

NICCHIA
> Battente con porta centrale

Hinged door with 2 in-line fixed panels
 Porte battante avec 2 parois alignées

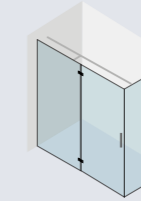

ANGOLO
> Battente + fisso laterale

Hinged door with in-line fixed panel + fixed side panel
 Porte battante avec paroi fixe alignée + côté fixe

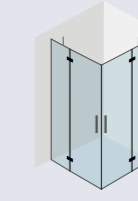

ANGOLO
> 2 battenti

2 hinged doors with in-line fixed panels
 2 portes battantes avec parois alignées

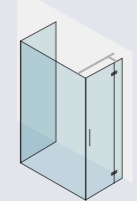

PARETE
> 3 lati

Hinged door with 2 fixed panels
 Porte battante avec côtés fixes

A richiesta (contattare ufficio tecnico):
On request (to be verified with technical department):
Sur demande (vérifier avec le département technique):

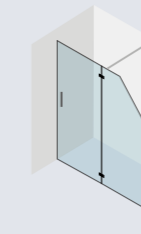

NICCHIA
> Battente + fisso laterale sottotetto

Porte battante + in-line fixed panel for sloped ceiling
 Porte battante + paroi fixe alignée pour plafond incliné

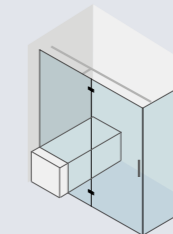

ANGOLO
> Battente con fisso sagomato + fisso laterale

Hinged door with shaped in-line panel + fixed side panel
 Porte battante avec paroi façonnée + paroi fixe latérale

Dettagli / details / détails



Maniglia:
Fissata al profilo, ha un design minimale e pratico.

Handle:
Fixed to the profile, it has a minimal and practical design.

Poignée:
Fixée au profilé, avec design minimal et pratique.



Profilo con chiusura magnetica:
Per una perfetta tenuta dell'acqua e una chiusura sicura.

Profile with magnetic closure:
for a perfect watertight, secure closure.

Profilé avec fermeture magnétique:
pour un excellente tenue de l'eau.



Apertura a 90° sia interna che esterna.
La superficie interna del vetro e la cerniera sono a filo. La cerniera è dotata di sistema di alzata.

Opening 90° both inward and outward.
The hinge is flush to the internal glass surface. The hinge is also equipped with a lifting system.

Ouverture de 90° tant vers l'intérieur que vers l'extérieur.
La charnière est à fleur avec le côté interne de la paroi. La charnière est équipée d'un système de relèvement.

04.

**Porta battente ad angolo
con fisso laterale**
brill + vetro trasparente

***Hinged door with in-line
fixed panel + fixed side panel***
in brill + trasparente glass

***Porte battante avec paroi
fixe alignée + côté fixe***
en brill + verre transparent



Piatto doccia:
Linear bianco L 120 x P 70 cm

Shower tray:
Linear bianco W 120 x D 70 cm

Receveur:
Linear bianco L 120 x P 70 cm



**Cerniere
Ibra:**
un design
esclusivo

**Ibra
hinges:**
an exclusive
design

**Charnière
Ibra:**
un design
exclusif

**Apertura
in/out**
per la massima
praticità

**In/out
opening**
for the best
confort

**Ouverture
in/out**
pour une praticité
maximale

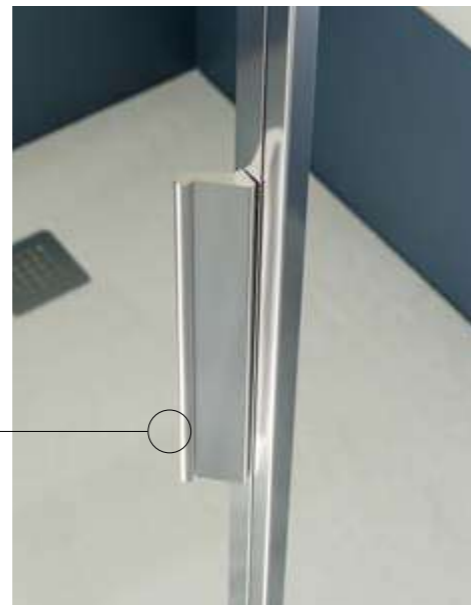

05.

**Porta battente
in nicchia**
nero + vetro con
serigrafia fascia

*Hinged door
in niche*
in nero + Fascia serigraphy

*Porte battante
en niche*
en nero + sérigraphie Fascia

Piatto doccia:
Parallel bianco L 140 x P 80 cm

Shower tray:
Parallel bianco W 140 x D 80 cm

Receveur:
Parallel bianco L 140 x P 80 cm





Tenuta all'acqua ottimale
grazie alla guarnizione con salvagoccia

High watertightness performance
thanks to the drip gasket

Excellente tenue de l'eau
grâce au joint contre l'éclaboussement

Maniglia "Ti" a vetro
come alternativa alla maniglia di serie

Glass-mounted "Ti" handle
as an alternative to the standard handle

Poignée "Ti" fixée au verre
alternative à la poignée de série



06.

**Porta battente ad angolo
con fisso laterale**
rodio + vetro grigio europa

*Hinged door with in-line fixed panel
+ fixed side panel*
in rodio + grigio europa glass

*Porte battante avec paroi fixe alignée
+ côté fixe*
en rodio + verre grigio europa

Piatto doccia:
Elle bianco L 120 x P 80 cm

Shower tray:
Elle bianco W 120 x D 80 cm

Receveur:
Elle bianco L 120 x P 80 cm





Facilità di pulizia
grazie alla cerniera a filo retro interno del box

Easy to clean
thanks to the inner side in-line hinge

Facile à nettoyer
grâce à la charnière coplanaire

Braccetto accorciabile in opera
dal design minimale

Stabilizing bar to be cut during installation
with minimal design

Barre de soutien avec design minimal,
à couper en cours d'installation



07.

**Doppia porta battente
ad angolo**
oro + vetro trasparente

**Double hinged door
+ in-line fixed panels**
in oro + trasparente glass

**Double porte battante
avec parois alignées**
en oro + verre transparente

Piatto doccia:
Linear bianco L 90 x P 90 cm

Shower tray:
Linear bianco W 90 x D 90 cm

Receveur:
Linear bianco L 90 x P 90 cm





Tappi coprivite in tinta
per un fi saggio a scomparsa

Matching screw caps

Couvre-vis assorti



ICON BATTENTE

Nicchia
Niche
Niche

Battente
Hinged door
Porte battante



APERTURA
IN/OUT

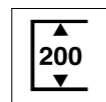

Altezza 200 cm
Height 200 cm
Hauteur 200 cm

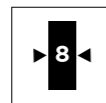

Vetro sp. 8 mm
Glass th. 8 mm
Verre ép. 8 mm



Fuori misura:
altezza max 220 cm / larghezza max 160 cm
Out of standard:
height max. 220 cm / width max. 160 cm
Sur demande:
hauteur max. 220 cm / largeur max. 160 cm



Braccetto accorciabile in opera compreso nel prezzo
Stabilizing bar to be cutted during installation included
Barre de soutien à couper en cours de réalisation comprise dans le prix.

Configurazioni:
Configurations:
Configurations:

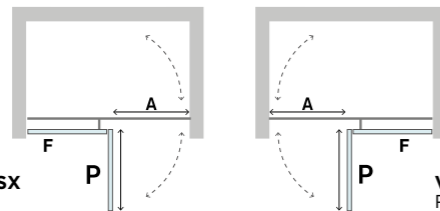

VERSIONE SX
Left
Gauche

VERSIONE DX
Right
Droite

ATTENZIONE!

La larghezza della porta (P) è data dall'apertura (A) + 3 cm.
Total width of the door (P) is given by width of opening (A) + 3 cm.
La largeur totale de la porte (P) est donnée par l'addition de l'ouverture (A) + 3 cm.

Fuori Misura:
Out of standard:
Sur mesure:



+ 30 %

(richiedere fattibilità)
(ask for feasibility)
(vérifier la faisabilité avec le service technique)

Trattamento anticalcare:
Glass treatment:
Traitement verre:



+ 80

Lato
Side
Verre

Vetro Extralight / Timeless:
Extralight/Timeless glass:
Verre Extralight/Timeless:



+ 40 %

Vetro con serigrafie:
Serigraphies (see page 371):
Sérigraphies (voir page 371):



+ 25 %

maggiorazione dal TRASPARENTE
increase on the TRASPARENTE price
à appliquer sur le prix du TRASPARENTE

Vetro Nuvola:
Nuvola glass (see page 371):
Verre Nuvola (voir page 371):



+ 7 / cm

Profili speciali:
Special profile :
Profils spéciaux

> BRONZO
> ORO SPAZZOLATO
> RAME
> RODIO LUCIDO
> INOX SPAZZOLATO



Lato
Side
Verre

ICON BATTENTE

Nicchia
Niche
Niche

Battente
Hinged door
Porte battante

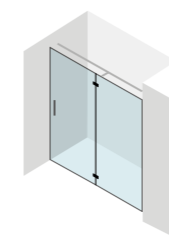

ATTENZIONE
Specificare il verso al momento dell'ordine.

ATTENTION
Indiquer le vers dans l'ordre.

ATTENTION
Indiquer le vers dans la commande.

P - PORTA BATTENTE / HINGED DOOR / PORTE BATTANTE

ART. ITEM ART.	ESTENSIBILITÀ EXTENSIBILITY EXTENSIBILITÉ	PIATTO TRAY RECEVEUR	APERTURA OPENING ENTRÉE	FISSO FIXED FIXE	PROFILO PROFILE PROFIL	VETRO/GLASS/VERRE TRASPARENTE	VETRO/GLASS/VERRE GRIGIO EUROPA SATIN - BRONZO
D8BN100	76 - 79	80	42	25	BRILL		
					NERO		
D8BN105	81 - 84	85	42	30	BRILL		
					NERO		
D8BN110	86 - 89	90	52	25	BRILL		
					NERO		
D8BN115	91 - 94	95	52	30	BRILL		
					NERO		
D8BN120	96 - 99	100	52	35	BRILL		
					NERO		
D8BN125	101 - 104	105	52	40	BRILL		
					NERO		
D8BN130	106 - 109	110	62	35	BRILL		
					NERO		
D8BN135	111 - 114	115	62	40	BRILL		
					NERO		
D8BN140	116 - 119	120	62	45	BRILL		
					NERO		
D8BN145	121 - 124	125	62	50	BRILL		
					NERO		
D8BN150	126 - 129	130	62	55	BRILL		
					NERO		
D8BN155	131 - 134	135	62	60	BRILL		
					NERO		
D8BN160	136 - 139	140	62	65	BRILL		
					NERO		

ICON BATTENTE

Nicchia
Niche
Niche

Battente con porta centrale
Hinged door with 2 fi ed panels in line
Porte battante avec 2 parois fi es alignées

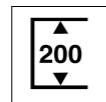

Altezza 200 cm
Height 200 cm
Hauteur 200 cm

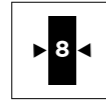

Vetro sp. 8 mm
Glass th. 8 mm
Verre ép. 8 mm



Fuori misura:
altezza max 220 cm / larghezza max 200 cm
Out of standard:
height max. 220 cm / width max. 200 cm
Sur demande:
hauteur max. 220 cm / largeur max. 200 cm



Braccetto accorciabile in opera compreso nel prezzo
Stabilizing bar to be cutted during installation included
Barre de soutien à couper en cours de réalisation comprise dans le prix.

Configurazioni:
Configurations:
Configurations:

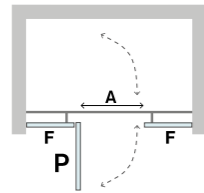

VERSIONE SX
Left
Gauche

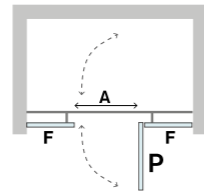

VERSIONE DX
Right
Droite

ATTENZIONE!

La larghezza della porta (P) è data dall'apertura (A) + 3 cm.
Total width of the door (P) is given by width of opening (A) + 3 cm.
La largeur totale de la porte (P) est donnée par l'addition de l'ouverture (A) + 3 cm

Fuori Misura:
Out of standard:
Sur mesure:



+ 30 %

(richiedere fattibilità)
(ask for feasibility)
(vérifier la faisabilité avec le service technique)

Trattamento anticalcare:
Glass treatment:
Traitement verre:



+ 80

Lato
Side
Verre

Vetro Extralight / Timeless:
Extralight/Timeless glass:
Verre Extralight/Timeless:



+ 40 %

Vetro con serigrafie:
Serigraphies (see page 371):
Sérigraphies (voir page 371):



+ 25 %

maggiorazione dal TRASPARENTE
increase on the TRASPARENTE price
à appliquer sur le prix du TRASPARENTE

Vetro Nuvola:
Nuvola glass (see page 371):
Verre Nuvola (voir page 371):



+ 7 / cm

Profili speciali:
Special profile :
Profils speciaux

- > BRONZO
- > ORO SPAZZOLATO
- > RAME
- > RODIO LUCIDO
- > INOX SPAZZOLATO



Lato
Side
Verre

ICON BATTENTE

Nicchia
Niche
Niche

Battente con porta centrale
Hinged door with 2 in line fi ed panels
Porte battante avec 2 parois fi es alignées

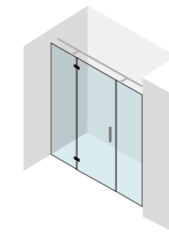

ATTENZIONE
Specificare il verso al momento dell'ordine.

ATTENTION
Indicate the side in the order.

ATTENTION
Indiquer le vers dans la commande.

P - PORTA BATTENTE / HINGED DOOR / PORTE BATTANTE

ART. ITEM ART.	ESTENSIBILITÀ EXTENSIBILITY EXTENSIBILITÉ	PIATTO TRAY RECEVEUR	APERTURA OPENING ENTRÉE	FISSO FIXED FIXE	PROFILO PROFILE PROFIL	VETRO/GLASS/VERRE TRASPARENTE	VETRO/GLASS/VERRE GRIGIO EUROPA SATIN - BRONZO
D8BN185	96 - 100	100	52	17	BRILL		
					NERO		
D8BN190	101 - 105	105	52	19	BRILL		
					NERO		
D8BN195	106 - 110	110	52	22	BRILL		
					NERO		
D8BN200	111 - 115	115	52	24	BRILL		
					NERO		
D8BN205	116 - 120	120	52	27	BRILL		
					NERO		
D8BN210	121 - 125	125	52	29	BRILL		
					NERO		
D8BN215	126 - 130	130	52	32	BRILL		
					NERO		
D8BN220	131 - 135	135	52	34	BRILL		
					NERO		
D8BN225	136 - 140	140	52	37	BRILL		
					NERO		
D8BN230	141 - 145	145	52	39	BRILL		
					NERO		
D8BN235	146 - 150	150	52	42	BRILL		
					NERO		
D8BN240	151 - 155	155	52	44	BRILL		
					NERO		
D8BN245	156 - 160	160	52	47	BRILL		
					NERO		

ICON BATTENTE

Angolo
Corner
Coin

Battente con fisso laterale

Hinged door with in-line fixed panel + fixed side panel
Porte battante avec paroi fixe alignée + côté fixe

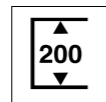

Altezza 200 cm
Height 200 cm
Hauteur 200 cm

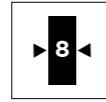

Vetro sp. 8 mm
Glass th. 8 mm
Verre ép. 8 mm



Fuori misura:
altezza max 220 cm / larghezza max 160 cm
Out of standard:
height max. 220 cm / width max. 160 cm
Sur demande:
hauteur max. 220 cm / largeur max. 160 cm



Braccetto accorciabile in opera compreso nel prezzo
Stabilizing bar to be cutted during installation included
Barre de soutien à couper en cours de réalisation comprise dans le prix.



Configurazioni:
Configurations:
Configurations:

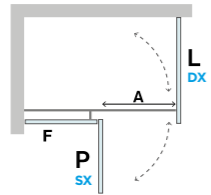

VERSIONE SX
Left
Gauche

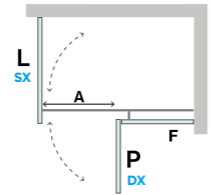

VERSIONE DX
Right
Droite

ATTENZIONE!

La larghezza della porta (P) è data dall'apertura (A) + 3 cm.
Total width of the door (P) is given by width of opening (A) + 3 cm.
La largeur totale de la porte (P) est donnée par l'addition de l'ouverture (A) + 3 cm

Fuori Misura:
Out of standard:
Sur mesure:

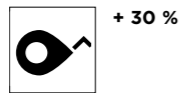

+ 30 %

(richiedere fattibilità)
(ask for feasibility)
(vérifier la faisabilité avec le service technique)

Trattamento anticalcare:
Glass treatment:
Traitement verre:

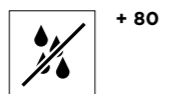

+ 80

Lato
Side
Verre

Vetro Extralight / Timeless:
Extralight/Timeless glass:
Verre Extralight/Timeless:



+ 40 %

Vetro con serigrafie:
Serigraphies (see page 371):
Sérigraphies (voir page 371):



+ 25 %

maggiorazione dal TRASPARENTE
increase on the TRASPARENTE price
à appliquer sur le prix du TRASPARENTE

Vetro Nuvola:
Nuvola glass (see page 371):
Verre Nuvola (voir page 371):



+ 7 / cm

Profili speciali:
Special profile :
Profils spéciaux

> BRONZO
> ORO SPAZZOLATO
> RAME
> RODIO LUCIDO
> INOX SPAZZOLATO



Porta
Door
Porte

Fisso
Fixed panel
Côté fixe

ICON BATTENTE

Angolo
Corner
Coin

Battente con fisso laterale

Hinged door with in-line fixed panel + fixed side panel
Porte battante avec paroi fixe alignée + côté fixe

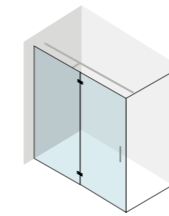

ATTENZIONE
Specificare il verso al momento dell'ordine.

ATTENTION
Indicate the side in the order.

ATTENTION
Indiquer le vers dans la commande.

P - PORTA BATTENTE / HINGED DOOR / PORTE BATTANTE

ART. ITEM ART.	ESTENSIBILITÀ EXTENSIBILITY EXTENSIBILITÉ	PIATTO TRAY RECEVEUR	APERTURA OPENING ENTRÉE	FISSO FIXED FIXE	PROFILO PROFILE PROFIL	VETRO/GLASS/VERRE TRASPARENTE	VETRO/GLASS/VERRE GRIGIO EUROPA SATIN - BRONZO
D8BA90	67,5 - 69,5	70	42	17	BRILL NERO		
D8BA95	72,5 - 74,5	75	42	22	BRILL NERO		
D8BA100	77,5 - 79,5	80	42	27	BRILL NERO		
D8BA105	82,5 - 84,5	85	42	32	BRILL NERO		
D8BA110	87,5 - 89,5	90	52	27	BRILL NERO		
D8BA115	92,5 - 94,5	95	52	32	BRILL NERO		
D8BA120	97,5 - 99,5	100	52	37	BRILL NERO		
D8BA125	102,5 - 104,5	105	52	42	BRILL NERO		
D8BA130	107,5 - 109,5	110	62	37	BRILL NERO		
D8BA135	112,5 - 114,5	115	62	42	BRILL NERO		
D8BA140	117,5 - 119,5	120	62	47	BRILL NERO		
D8BA145	122,5 - 124,5	125	62	52	BRILL NERO		
D8BA150	127,5 - 129,5	130	62	57	BRILL NERO		
D8BA155	132,5 - 134,5	135	62	62	BRILL NERO		
D8BA160	137,5 - 139,5	140	62	67	BRILL NERO		

L - FISSO / FIXED PANEL / CÔTÉ FIXE

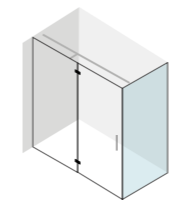

ATTENZIONE
Specificare il verso al momento dell'ordine.

ATTENTION
Indicate the side in the order.

ATTENTION
Indiquer le vers dans la commande.

ART. ITEM ART.	ESTENSIBILITÀ EXTENSIBILITY EXTENSIBILITÉ	PIATTO TRAY RECEVEUR			PROFILO PROFILE PROFIL	VETRO/GLASS/VERRE TRASPARENTE	VETRO/GLASS/VERRE GRIGIO EUROPA SATIN - BRONZO
D8BA165	67,5 - 69,5	70			BRILL NERO		
D8BA170	72,5 - 74,5	75			BRILL NERO		
D8BA175	77,5 - 79,5	80			BRILL NERO		
D8BA180	82,5 - 84,5	85			BRILL NERO		
D8BA185	87,5 - 89,5	90			BRILL NERO		
D8BA190	92,5 - 94,5	95			BRILL NERO		
D8BA195	97,5 - 99,5	100			BRILL NERO		

ICON BATTENTE

Angolo
Corner
Coin

2 porte battenti
2 hinged doors
2 portes battantes

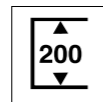

Altezza 200 cm
Height 200 cm
Hauteur 200 cm

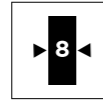

Vetro sp. 8 mm
Glass th. 8 mm
Verre ép. 8 mm



Fuori misura:
altezza max 220 cm / larghezza max 120 cm
Out of standard:
height max. 220 cm / width max. 120 cm
Sur demande:
hauteur max. 220 cm / largeur max. 120 cm

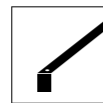

Braccetti a 45° (inclusi nel prezzo)
Stabilizing bars 45° (included)
Barres de soutien à 45° (incluses)



Configurazioni:
Configurations:
Configurations:

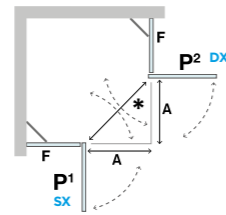

VERSIONE SX / DX
Left / Right
Gauche / Droite

Fuori Misura:
Out of standard:
Sur mesure:



+ 30 %

(richiedere fattibilità)
(ask for feasibility)
(vérifier la faisabilité avec le service technique)

Trattamento anticalcare:
Glass treatment:
Traitement verre:



+ 80

Lato
Side
Verre

Vetro Extralight / Timeless:
Extralight/Timeless glass:
Verre Extralight/Timeless:



+ 40 %

Vetro con serigrafie:
Serigraphies (see page 371):
Sérigraphies (voir page 371):



+ 25 %

maggiorazione dal TRASPARENTE
increase on the TRASPARENTE price
à appliquer sur le prix du TRASPARENTE

Vetro Nuvola:
Nuvola glass (see page 371):
Verre Nuvola (voir page 371):



+ 7 / cm

Profili speciali:
Special profile :
Profils spéciaux

> BRONZO
> ORO SPAZZOLATO
> RAME
> RODIO LUCIDO
> INOX SPAZZOLATO



Lato
Side
Verre

ICON BATTENTE

Angolo
Corner
Coin

2 porte battenti
2 hinged doors
2 portes battantes

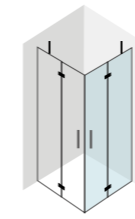

ATTENZIONE
Specificare il verso al momento dell'ordine.

ATTENTION
Indicate the side in the order.

ATTENTION
Indiquer le vers dans la commande.

P1 / P2 - PORTA BATTENTE / HINGED DOOR / PORTE BATTANTE

ART. ITEM ART.	ESTENSIBILITÀ EXTENSIBILITÉ	PIATTO TRAY RECEVEUR	APERTURA OPENING ENTRÉE	FISSO FIXED FIXE	PROFILO PROFILE PROFIL	VETRO/GLASS/VERRE TRASPARENTE	VETRO/GLASS/VERRE GRIGIO EUROPA SATIN - BRONZO
D8BA200	67,5 - 69,5	70	35	28	BRILL NERO		
D8BA205	72,5 - 74,5	75	35	33	BRILL NERO		
D8BA210	77,5 - 79,5	80	45	28	BRILL NERO		
D8BA215	82,5 - 84,5	85	45	33	BRILL NERO		
D8BA220	87,5 - 89,5	90	55	28	BRILL NERO		
D8BA225	92,5 - 94,5	95	55	33	BRILL NERO		
D8BA230	97,5 - 99,5	100	55	38	BRILL NERO		
D8BA235	102,5 - 104,5	105	55	43	BRILL NERO		
D8BA240	107,5 - 109,5	110	65	38	BRILL NERO		
D8BA245	112,5 - 114,5	115	65	43	BRILL NERO		
D8BA250	117,5 - 119,5	120	65	48	BRILL NERO		

ATTENZIONE!

Per il calcolo del prezzo totale vanno sommati 2 lati.

ATTENTION!

The total price is given by the addition of 2 sides.

ATTENTION!

Le prix total est donné par l'addition des 2 côtés.

DIMENSIONI APERTURA (*):
ENTRANCE DIMENSIONS (*):
DIMENSIONS DE PASSAGE (*):

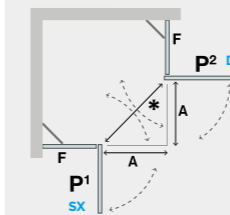

	70	75	80	85	90	95	100	105	110	115	120
70	49	57			65					74	
75											
80	57	64			71					79	
85											
90											
95	65	71			79					85	
100											

ICON BATTENTE

Parete
Wall
Mur

3 lati
3 sides
3 côtés

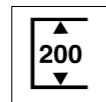

Altezza 200 cm
Height 200 cm
Hauteur 200 cm

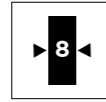

Vetro sp. 8 mm
Glass th. 8 mm
Verre ép. 8 mm



Fuori misura:
altezza max 220 cm / larghezza max 120 cm / profondità max 100 cm
Out of standard:
height max. 220 cm / width max. 120 cm / depth max. 100 cm
Sur demande:
hauteur max. 220 cm / largeur max. 120 cm / profondeur max. 100 cm



Braccetto accorciabile in opera compreso nel prezzo
Stabilizing bar to be cutted during installation included
Barre de soutien à couper en cours de réalisation comprise dans le prix



Configurazioni:
Configurations:
Configurations:

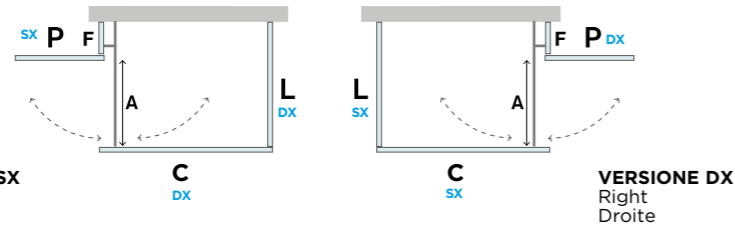

Fuori Misura:
Out of standard:
Sur mesure:

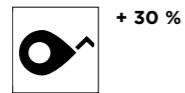

(richiedere fattibilità)
(ask for feasibility)
(vérifier la faisabilité avec le service technique)

Trattamento anticalcare:
Glass treatment:
Traitement verre:



Lato
Side
Verre

Vetro Extralight / Timeless:
Extralight/Timeless glass:
Verre Extralight/Timeless:



Vetro con serigrafie:
Serigraphies (see page 371):
Sérigraphies (voir page 371):



maggiorazione dal TRASPARENTE
increase on the TRASPARENTE price
à appliquer sur le prix du TRASPARENTE

Vetro Nuvola:
Nuvola glass (see page 371):
Verre Nuvola (voir page 371):



Profili speciali:
Special profile :
Profils spéciaux

- > BRONZO
- > ORO SPAZZOLATO
- > RAME
- > RODIO LUCIDO
- > INOX SPAZZOLATO



Porta
Door
Porte

Fisso
Fixed panel
Côté fixe

ICON BATTENTE

Parete
Wall
Mur

3 lati
3 sides
3 côtés

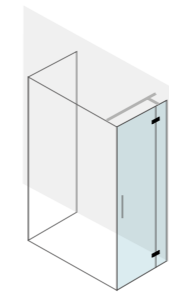

ATTENZIONE
Specificare il verso al momento dell'ordine.

ATTENTION
Indicate the side in the order.

ATTENTION
Indiquer le vers dans la commande.

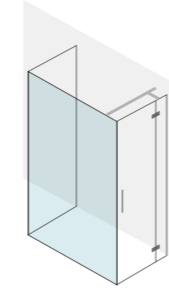

ATTENZIONE
Specificare il verso al momento dell'ordine.

ATTENTION
Indicate the side in the order.

ATTENTION
Indiquer le vers dans la commande.

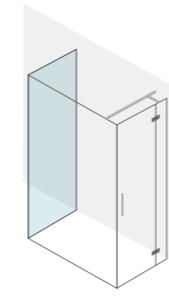

ATTENZIONE
Specificare il verso al momento dell'ordine.

ATTENTION
Indicate the side in the order.

ATTENTION
Indiquer le vers dans la commande.

P - PORTA BATTENTE / HINGED DOOR / PORTE BATTANTE

ART. ITEM ART.	ESTENSIBILITÀ EXTENSIBILITY EXTENSIBILITÉ	PIATTO TRAY RECEVEUR	APERTURA OPENING ENTRÉE	FISSO FIXED FIXE	PROFILO PROFILE PROFIL	VETRO/GLASS/VERRE TRASPARENTE	VETRO/GLASS/VERRE GRIGIO EUROPA SATIN - BRONZO
D8BA90	67,5 - 69,5	70	42	17	BRILL NERO		
D8BA95	72,5 - 74,5	75	42	22	BRILL NERO		
D8BA100	77,5 - 79,5	80	42	27	BRILL NERO		
D8BA105	82,5 - 84,5	85	42	32	BRILL NERO		
D8BA110	87,5 - 89,5	90	52	27	BRILL NERO		
D8BA115	92,5 - 94,5	95	52	32	BRILL NERO		
D8BA120	97,5 - 99,5	100	52	37	BRILL NERO		

C - FISSO CENTRALE / FIXED CENTRAL PANEL / CÔTÉ FIX CENTRAL

ART. ITEM ART.	ESTENSIBILITÀ EXTENSIBILITY EXTENSIBILITÉ	PIATTO TRAY RECEVEUR	APERTURA OPENING ENTRÉE	FISSO FIXED FIXE	PROFILO PROFILE PROFIL	VETRO/GLASS/VERRE TRASPARENTE	VETRO/GLASS/VERRE GRIGIO EUROPA SATIN - BRONZO
D8BP100	78	80			BRILL NERO		
D8BP105	83	85			BRILL NERO		
D8BP110	88	90			BRILL NERO		
D8BP115	93	95			BRILL NERO		
D8BP120	98	100			BRILL NERO		
D8BP125	103	105			BRILL NERO		
D8BP130	108	110			BRILL NERO		
D8BP135	113	115			BRILL NERO		
D8BP140	118	120			BRILL NERO		
D8BP145	123	125			BRILL NERO		
D8BP150	128	130			BRILL NERO		
D8BP155	133	135			BRILL NERO		
D8BP160	138	140			BRILL NERO		

L - FISSO / FIXED LATERAL PANEL / CÔTÉ FIXE LATÉRAL

ART. ITEM ART.	ESTENSIBILITÀ EXTENSIBILITY EXTENSIBILITÉ	PIATTO TRAY RECEVEUR	APERTURA OPENING ENTRÉE	FISSO FIXED FIXE	PROFILO PROFILE PROFIL	VETRO/GLASS/VERRE TRASPARENTE	VETRO/GLASS/VERRE GRIGIO EUROPA SATIN - BRONZO
D8WP155	67,5 - 69,5	70			BRILL NERO		
D8WP160	72,5 - 74,5	75			BRILL NERO		
D8WP165	77,5 - 79,5	80			BRILL NERO		
D8WP170	82,5 - 84,5	85			BRILL NERO		
D8WP175	87,5 - 89,5	90			BRILL NERO		
D8WP180	92,5 - 94,5	95			BRILL NERO		
D8WP185	97,5 - 99,5	100			BRILL NERO		

ICON: **SCORREVOLE SLIDING DOOR COULISSANTE**

LEGENDA KEY / LÉGENDE

F fi so / fi ed panel / côté fi e
L lato / fi ed panel lateral / côté fi e latéral
A apertura / opening / entrée
P porta / door / porte



Scopri le caratteristiche tecniche
 Discover the technical features
 Découvrez les caractéristiques techniques



ICON **SCORREVOLE**

Di serie:
 Standard:
 De série:



NICCHIA
 > Scorrevole

1 sliding door
 + fixed panel

Porte coulissante



ANGOLO
 > Scorrevole 1 porta
 + fisso laterale

1 sliding door
 + fixed panel

Porte coulissante
 + côté fixe

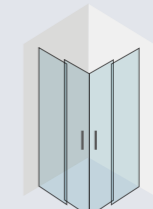

ANGOLO
 > Scorrevole
 2 porte

2 sliding doors

2 portes coulissantes

A richiesta
 (contattare ufficio tecnico):
 On request
 (to be verified with technical department):
 Sur demande
 (vérifier avec le département technique):

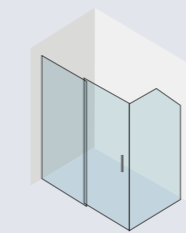

ANGOLO
 > Scorrevole + fisso
 laterale sottotetto

Sliding door with in-line fixed panel + side panel for sloped ceiling

Porte coulissante avec paroi fixe alignée + paroi fixe latérale pour plafond incliné

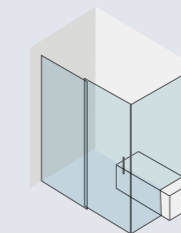

ANGOLO
 > Scorrevole sagomato + fisso laterale

Sliding door with in-line fixed panel + shaped fixed lateral panel

Porte coulissante avec paroi fixe alignée + paroi fixe latérale façonnée

Dettagli / details / détails



Angolo a 45°:
 Il giunto a 45° è il punto d'incontro dei profili perimetrali.

45° degrees:
 The 45° joint is the point where the perimeter profiles meet.

45° degrés:
 Le joint à 45° est le point d'incontro des profils perimetraux.



Sgancio della porta:
 Un sistema utile per facilitare le operazioni di pulizia.

Quick release system:
 A useful system for the cleaning operations.

Décrochage de la porte:
 Un système utile pour le nettoyage.



Sistema scorrevole con doppia rotella:
 Facilita e rende silenzioso lo scorrimento delle porte in apertura e chiusura.

Sliding system with double roller:
 It makes the sliding of the doors easier and silent both for opening and closing.

Système coulissant à double roulette:
 Il rend le glissement des portes en ouverture et fermeture plus aisé et il réduit le bruit.



Il modello Icon scorrevole è fornito di un sistema di ammortizzazione in apertura che attutisce e accompagna il movimento. Lo scorrimento è reso fluido e silenzioso da 4 rotelle con cuscinetti in acciaio inox.

The sliding Icon model is equipped with an opening cushioning system which softens and accompanies the movement. The sliding is made smooth and silent by 4 wheels with stainless steel bearings.

Le modèle Icon coulissant est équipé d'un système d'amortissement à l'ouverture qui accompagne le mouvement. Le coulissement est rendu fluide et silencieux par 4 roues à roulements inox.

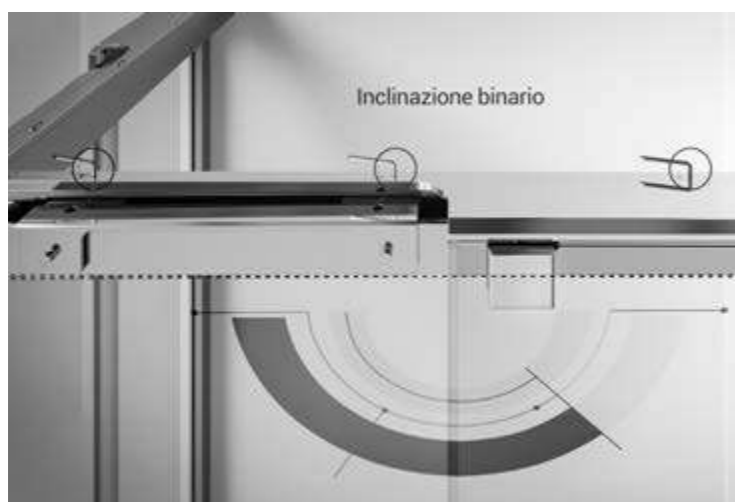

La regolazione della messa in bolla del binario superiore è semplice e durevole nel tempo. Eventuali regolazioni successive possono essere effettuate senza smontare il box doccia.

The adjustment of the upper rail is simple and long-lasting. Any further adjustments can be made without disassembling the shower box.

Le réglage du rail supérieur est simple et durable. Tout réglage suivant peut être effectué sans démonter la cabine de douche.



Anche a montaggio ultimato è possibile regolare l'inclinazione della porta.

The inclination of the door can also be adjusted once the assembly is complete.

L'inclinaison de la porte peut également être ajustée une fois l'assemblage terminé.



Il sistema di scorrimento con sgancio, unico nel mercato, consente di mettere in bolla il vetro fisso anche in caso di piattini male installati o deformati.

The sliding system with release, a unique feature on the market, allows the fixed glass to be adjusted even in the case of incorrectly installed or deformed plates.

Le système coulissant avec déblocage, caractéristique unique sur le marché, permet de régler le verre fixe même en cas de receveurs mal installés ou déformés.



Il fissaggio del vetro sul profilo a muro avviene senza l'utilizzo di silicone. La traversa non è fissata a muro, facilitandone l'installazione.

The glass is fixed to the wall profile without the use of silicone. The crossbar is self-supporting, thus making the installation easier.

Le verre est fixé au profilé mural sans utiliser du silicone. La barre transversale est autoportante, ce qui facilite l'installation.

08.

**Porta scorrevole ad angolo
+ fisso laterale**
nero + vetro grigio europa

*Sliding door + fixed lateral panel
+ fixed panel*
in nero + grigio europa glass

*Porte coulissante
+ côté fixe lateral*
en nero + verre grigio europa

Piatto doccia:
Aureo Laminam Bianco Assoluto
L 140 x P 90 cm

Shower tray:
Aureo Laminam Bianco Assoluto
W 140 x D 90 cm

Receveur:
Aureo Laminam Bianco Assoluto
L 140 x P 90 cm

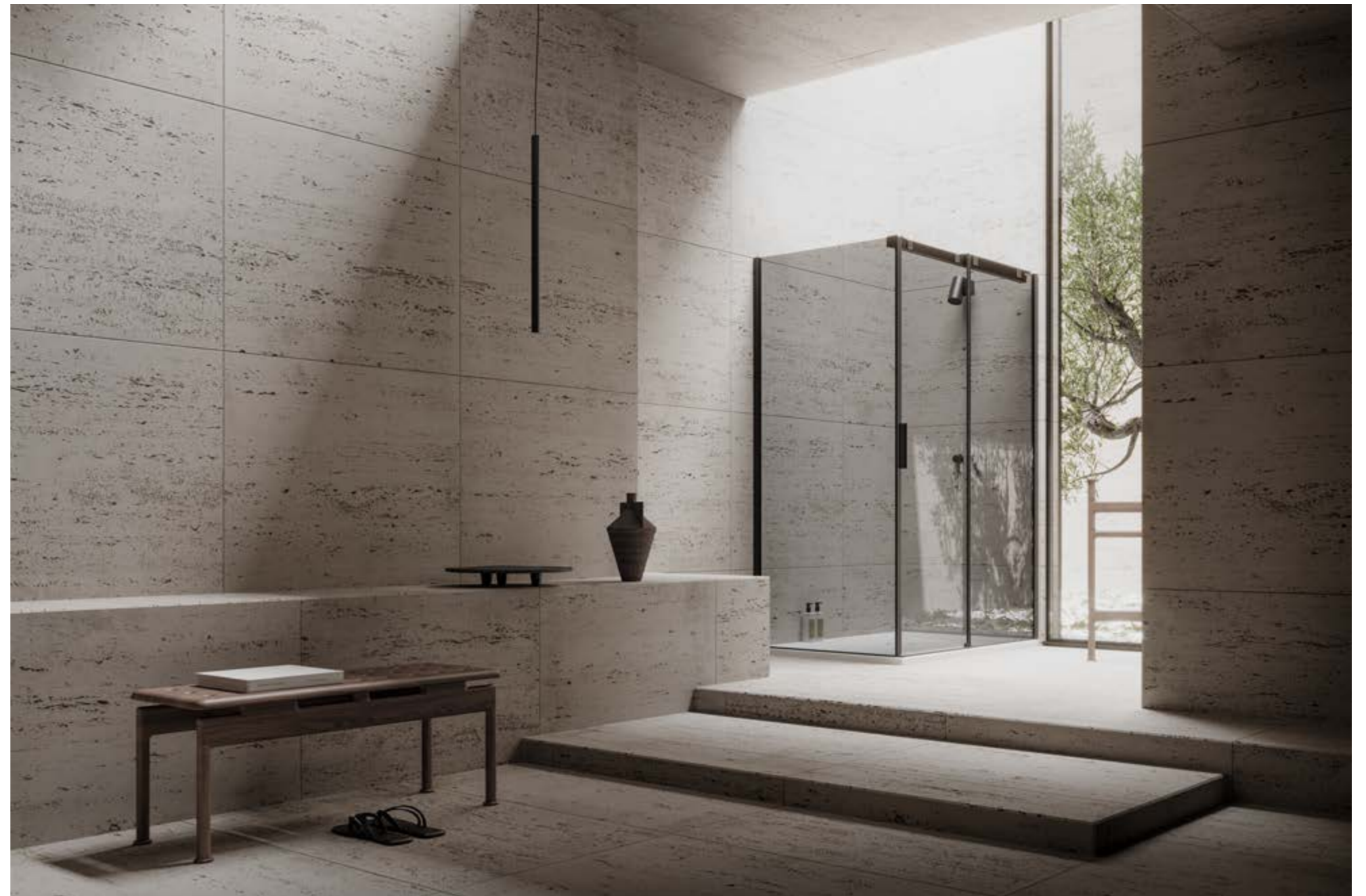



Sgancio rapido della porta
per agevolare
la pulizia

Quick release system
to easily clean

Décrochage rapide de la porte
pour simplifier le net oyage



09.

**Porta scorrevole
in nicchia**
bronzo + vetro trasparente

*Sliding door
in niche*
in bronzo + trasparente glass

*Porte coulissante
en niche*
en bronzo + verre transparente

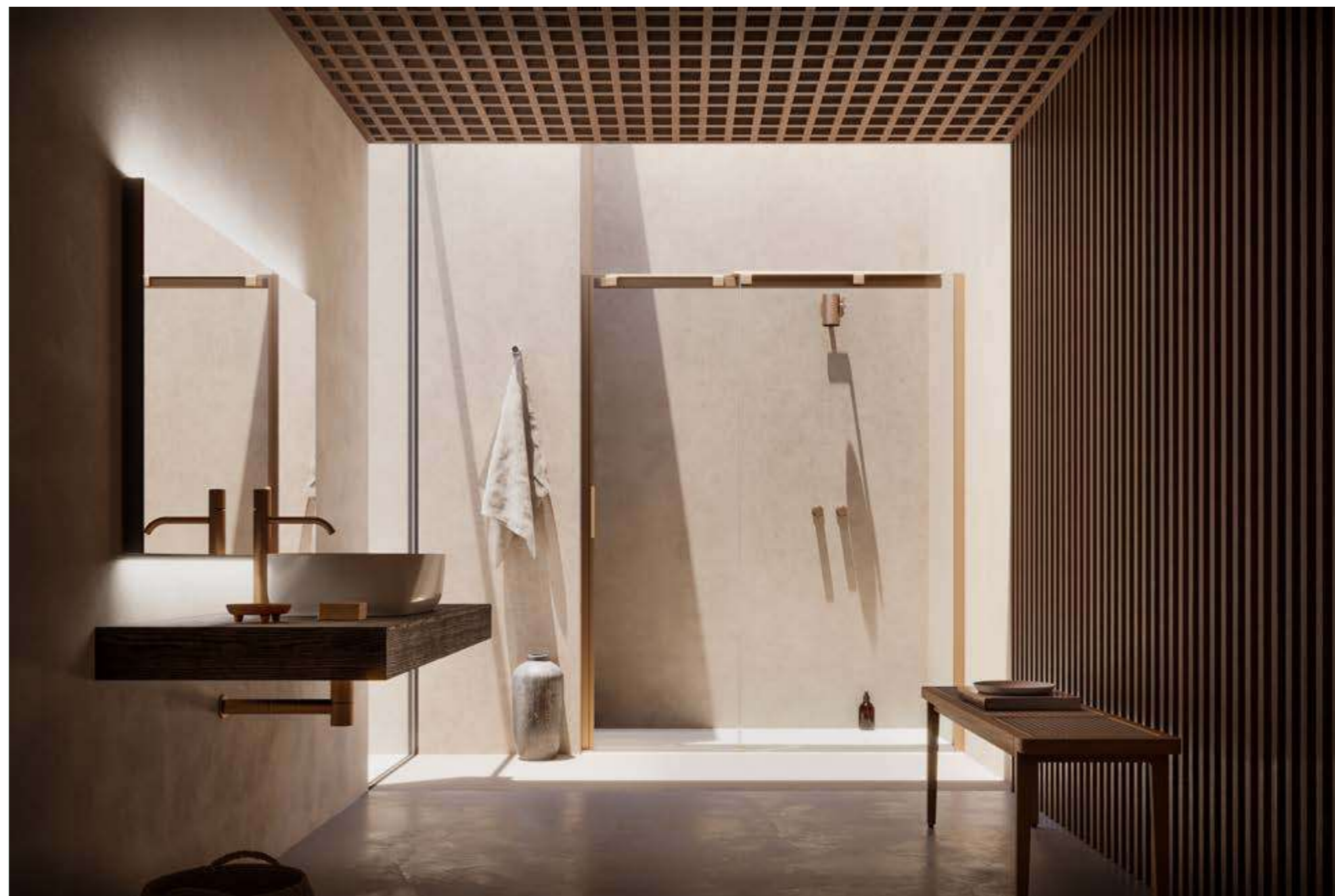

Piatto doccia:
Aureo Laminam Bianco Assoluto
L 160 x P 80 cm

Shower tray:
Aureo Laminam Bianco Assoluto
W 160 x D 80 cm

Receveur:
Aureo Laminam Bianco Assoluto
L 160 x P 80 cm



**Nessun fissaggio
della traversa
a muro**
per un montaggio
più rapido

**No fixing of the crossbar
to the wall**
for a faster
assembly

**Pas de fixation au mûr
de la barre transversale**
pour un montage plus rapide





10.

**Doppia porta scorrevole
ad angolo**
inox satinato + vetro trasparente

*2 sliding doors
in inox satinato + trasparente glass*

*2 porte coulissantes
en coin
inox satinato + verre transparente*

Piatto doccia:
Elle bianco L 90 x P 90 cm

*Shower tray:
Elle bianco W 90 x D 90 cm*

*Receveur:
Elle bianco L 90 x P 90 cm*



**Maniglia
lineare ed
ergonomica**
fi sata al
profilo del b x

**Linear and
ergonomic handle**
fi ed to
the box profil

**Poignée linéaire
et ergonomique**
fi ée au profil
de la paroi



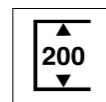

Altezza 200 cm
Height 200 cm
Hauteur 200 cm

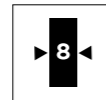

Vetro sp. 8 mm
Glass th. 8 mm
Verre ép. 8 mm



Fuori misura:
altezza max 220 cm / larghezza max 160 cm
Out of standard:
height max. 220 cm / width max. 160 cm
Sur demande:
hauteur max. 220 cm / largeur max. 160 cm

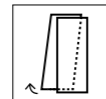

Sgancio rapido della porta
Door with quick release system
Décrochage rapide de la porte



Regolazione profilo superiore e inferiore
Profile adjustment upper and lower
Réglage du profil supérieur et inférieur



Sistema di scorrimento silenzioso di serie
Silent sliding system as standard
Système coulissant silencieux de série

Configurazioni:
Configurations:
Configurations:

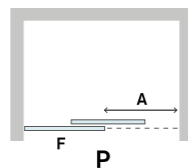

VERSIONE SX
Left
Gauche

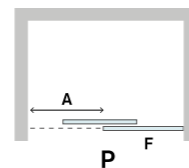

VERSIONE DX
Right
Droite

Fuori Misura:
Out of standard:
Sur mesure:



+ 30 %

(richiedere fattibilità)
(ask for feasibility)
(vérifier la faisabilité avec le service technique)

Trattamento anticalcare:
Glass treatment:
Traitement verre:



+ 80

Lato
Side
Verre

Vetro Extralight / Timeless:
Extralight/Timeless glass:
Verre Extralight/Timeless:



+ 40 %

Vetro con serigrafie:
Serigraphies (see page 371):
Sérigraphies (voir page 371):



+ 25 %

maggiorazione dal TRASPARENTE
increase on the TRASPARENTE price
à appliquer sur le prix du TRASPARENTE

Vetro Nuvola:
Nuvola glass (see page 371):
Verre Nuvola (voir page 371):



+ 7 / cm

Profili speciali:
Special profile :
Profils spéciaux

- > BRONZO
- > ORO SPAZZOLATO
- > RODIO LUCIDO
- > INOX SPAZZOLATO

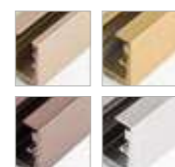

Lato
Side
Verre

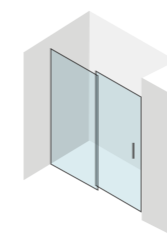

ATTENZIONE
Specificare il verso al momento dell'ordine.

ATTENTION
Indicate the side in the order.

ATTENTION
Indiquer le vers dans la commande.

P - PORTA SCORREVOLE / SLIDING DOOR / PORTE COULISSANTE

ART. ITEM ART.	ESTENSIBILITÀ EXTENSIBILITY EXTENSIBILITÉ	PIATTO TRAY RECEVEUR	APERTURA OPENING ENTRÉE	FISSO FIXED FIXE	PROFILO PROFILE PROFIL	VETRO/GLASS/VERRE	
						TRASPARENTE	GRIGIO EUROPA SATIN - BRONZO
D8SN100	96 - 99	100	41	47	BRILL		
					NERO		
D8SN105	101 - 104	105	41	52	BRILL		
					NERO		
D8SN110	106 - 109	110	41	57	BRILL		
					NERO		
D8SN115	111 - 114	115	41	62	BRILL		
					NERO		
D8SN120	116 - 119	120	51	57	BRILL		
					NERO		
D8SN125	121 - 124	125	51	62	BRILL		
					NERO		
D8SN130	126 - 129	130	56	62	BRILL		
					NERO		
D8SN135	131 - 134	135	56	67	BRILL		
					NERO		
D8SN140	136 - 139	140	56	72	BRILL		
					NERO		
D8SN145	141 - 144	145	56	77	BRILL		
					NERO		
D8SN150	146 - 149	150	56	82	BRILL		
					NERO		
D8SN155	151 - 154	155	56	87	BRILL		
					NERO		
D8SN160	156 - 159	160	56	92	BRILL		
					NERO		

ICON SCORREVOLE

Angolo
Corner
Coin

Porta scorrevole + fisso laterale
Sliding door + fi ed lateral panel
Porte coulissante + côté fi e latéral

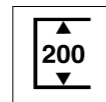

Altezza 200 cm
Height 200 cm
Hauteur 200 cm

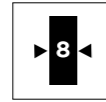

Vetro sp. 8 mm
Glass th. 8 mm
Verre ép. 8 mm



Fuori misura:
altezza max 220 cm / larghezza max 160 cm / profondità max 100 cm
Out of standard:
height max. 220 cm / width max. 160 cm /
depth max. 100 cm
Sur demande:
hauteur max. 220 cm / largeur max. 160 cm /
profondeur max. 100 cm

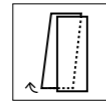

Sgancio rapido della porta
Door with quick release system
Décrochage rapide de la porte



Regolazione profilo superiore e inferiore
Profile adjustment upper and lower
Réglage du profil supérieur et inférieur



Sistema di scorrimento silenzioso di serie
Silent sliding system as standard
Système coulissant silencieux de série

Configurazioni:
Configurations:
Configurations:

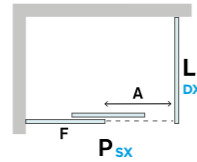

VERSIONE SX
Left
Gauche

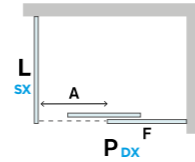

VERSIONE DX
Right
Droite

Fuori Misura:
Out of standard:
Sur mesure:

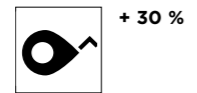

+ 30 %

(richiedere fattibilità)
(ask for feasibility)
(vérifier la faisabilité avec le service technique)

Trattamento anticalcare:
Glass treatment:
Traitement verre:

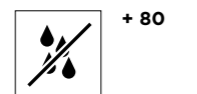

+ 80

Lato
Side
Verre

Vetro Extralight / Timeless:
Extralight/Timeless glass:
Verre Extralight/Timeless:



+ 40 %

Vetro con serigrafie:
Serigraphies (see page 371):
Sérigraphies (voir page 371):



maggiorazione dal TRASPARENTE
increase on the TRASPARENTE price
à appliquer sur le prix du TRASPARENTE

Vetro Nuvola:
Nuvola glass (see page 371):
Verre Nuvola (voir page 371):



+ 7 / cm

Profili speciali:
Special profile :
Profils spéciaux

> BRONZO
> ORO SPAZZOLATO
> RODIO LUCIDO
> INOX SPAZZOLATO

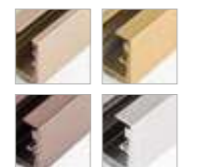

Porta
Door
Porte

Fisso
Fixed panel
Côté fixe

ICON SCORREVOLE

Angolo
Corner
Coin

Porta scorrevole + fisso laterale
Sliding door + fi ed panel
Porte coulissante + côté fi e

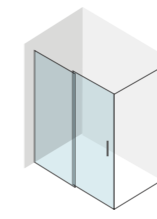

ATTENZIONE
Specificare il verso al momento dell'ordine.

ATTENTION
Indicate the side in the order.

ATTENTION
Indiquer le vers dans la commande.

P - PORTA SCORREVOLE / SLIDING DOOR / PORTE COULISSANTE

ART. ITEM ART.	ESTENSIBILITÀ EXTENSIBILITY EXTENSIBILITÉ	PIATTO TRAY RECEVEUR	APERTURA OPENING ENTRÉE	FISSO FIXED FIXE	PROFILO PROFILE PROFIL	VETRO/GLASS/VERRE TRASPARENTE	VETRO/GLASS/VERRE GRIGIO EUROPA SATIN - BRONZO
D8SA300	97,5 - 99,5	100	44	47	BRILL		
					NERO		
D8SA305	102,5 - 104,5	105	44	52	BRILL		
					NERO		
D8SA310	107,5 - 109,5	110	44	57	BRILL		
					NERO		
D8SA315	112,5 - 114,5	115	44	62	BRILL		
					NERO		
D8SA320	117,5 - 119,5	120	54	57	BRILL		
					NERO		
D8SA325	122,5 - 124,5	125	54	62	BRILL		
					NERO		
D8SA330	127,5 - 129,5	130	58	62	BRILL		
					NERO		
D8SA335	132,5 - 134,5	135	58	67	BRILL		
					NERO		
D8SA340	137,5 - 139,5	140	58	72	BRILL		
					NERO		
D8SA345	142,5 - 144,5	145	58	77	BRILL		
					NERO		
D8SA350	147,5 - 149,5	150	58	82	BRILL		
					NERO		
D8SA355	152,5 - 154,5	155	58	87	BRILL		
					NERO		
D8SA360	157,5 - 159,5	160	58	92	BRILL		
					NERO		

L - FISSO / FIXED LATÉRAL PANEL / CÔTÉ FIXE LATÉRAL

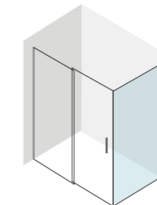

ATTENZIONE
Specificare il verso al momento dell'ordine.

ATTENTION
Indicate the side in the order.

ATTENTION
Indiquer le vers dans la commande.

ART. ITEM ART.	ESTENSIBILITÀ EXTENSIBILITY EXTENSIBILITÉ	PIATTO TRAY RECEVEUR			PROFILO PROFILE PROFIL	VETRO/GLASS/VERRE TRASPARENTE	VETRO/GLASS/VERRE GRIGIO EUROPA SATIN - BRONZO
D8SA365	67,5 - 69,5	70			BRILL		
					NERO		
D8SA370	72,5 - 74,5	75			BRILL		
					NERO		
D8SA375	77,5 - 79,5	80			BRILL		
					NERO		
D8SA380	82,5 - 84,5	85			BRILL		
					NERO		
D8SA385	87,5 - 89,5	90			BRILL		
					NERO		
D8SA390	92,5 - 94,5	95			BRILL		
					NERO		
D8SA395	97,5 - 99,5	100			BRILL		
					NERO		

ICON SCORREVOLE

Angolo
Corner
Coin

2 porte scorrevoli
2 sliding door
2 portes coulissantes

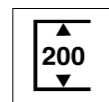

Altezza 200 cm
Height 200 cm
Hauteur 200 cm



Vetro sp. 8 mm
Glass th. 8 mm
Verre ép. 8 mm



Fuori misura:
altezza max 220 cm / larghezza max 120 cm
Out of standard:
height max. 220 cm / width max. 120 cm
Sur demande:
hauteur max. 220 cm / largeur max. 120 cm

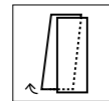

Sgancio rapido della porta
Door with quickrelease system
Décrochage rapide de la porte



Regolazione profilo superiore e inferiore
Profile adjustment upper and lower
Réglage du profil supérieur et inférieur



Sistema di scorrimento silenzioso di serie
Silent sliding system as standard
Système coulissant silencieux de série

Configurazioni:
Configurations:
Configurations:

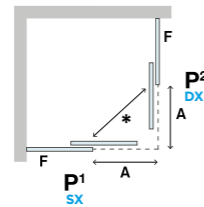

VERSIONE SX /DX
Left / Right
Gauche / Droite

Fuori Misura:
Out of standard:
Sur mesure:



+ 30 %

(richiedere fattibilità)
(ask for feasibility)
(vérifier la faisabilité avec le service technique)

Trattamento anticalcare:
Glass treatment:
Traitement verre:



+ 80

Lato
Side
Verre

Vetro Extralight / Timeless:
Extralight/Timeless glass:
Verre Extralight/Timeless:



+ 40 %

Vetro con serigrafie:
Serigraphies (see page 371):
Sérigraphies (voir page 371):



maggiorazione dal TRASPARENTE
increase on the TRASPARENTE price
à appliquer sur le prix du TRASPARENTE

Vetro Nuvola:
Nuvola glass (see page 371):
Verre Nuvola (voir page 371):



+ 7 / cm

Profili speciali:
Special profile :
Profils spéciaux

- > BRONZO
- > ORO SPAZZOLATO
- > RODIO LUCIDO
- > INOX SPAZZOLATO

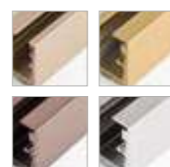

Lato
Side
Verre

ICON SCORREVOLE

Angolo
Corner
Coin

2 porte scorrevoli
2 sliding door
2 portes coulissantes



ATTENZIONE
Specificare il verso al momento dell'ordine.

ATTENTION
Indicate the side in the order.

ATTENTION
Indiquer le vers dans la commande.

P1 / P2 - PORTA SCORREVOLE / SLIDING DOOR / PORTE COULISSANTE

ART. ITEM ART.	ESTENSIBILITÀ EXTENSIBILITY EXTENSIBILITÉ	PIATTO TRAY RECEVEUR	APERTURA OPENING ENTRÉE	FISSO FIXED FIXE	PROFILO PROFILE PROFIL	VETRO/GLASS/VERRE TRASPARENTE	VETRO/GLASS/VERRE GRIGIO EUROPA SATIN - BRONZO
D8SA210	77,5 - 79,5	80	32	38	BRILL NERO		
D8SA215	82,5 - 84,5	85	32	43	BRILL NERO		
D8SA220	87,5 - 89,5	90	37	43	BRILL NERO		
D8SA225	92,5 - 94,5	95	37	48	BRILL NERO		
D8SA230	97,5 - 99,5	100	37	53	BRILL NERO		
D8SA235	102,5 - 104,5	105	37	58	BRILL NERO		
D8SA240	107,5 - 109,5	110	37	63	BRILL NERO		
D8SA245	112,5 - 114,5	115	37	68	BRILL NERO		
D8SA250	117,5 - 119,5	120	37	73	BRILL NERO		

ATTENZIONE!
Per il calcolo del prezzo totale vanno sommati 2 lati.



ATTENTION!
The total price is given by the addition of 2 sides.



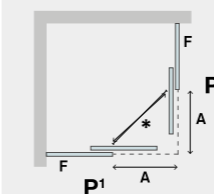

ATTENTION!
Le prix total est donné par l'addition des 2 côtés.

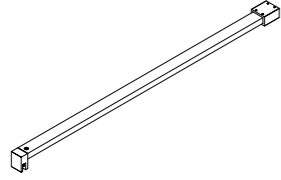
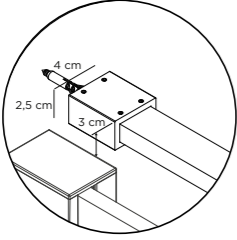
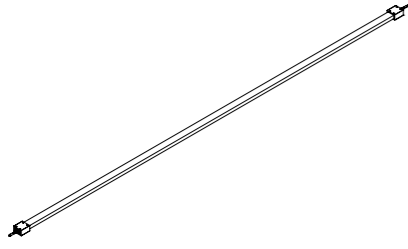
DIMENSIONI APERTURA (*):
ENTRANCE DIMENSIONS (*):
DIMENSIONS DE PASSAGE (*):

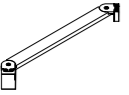
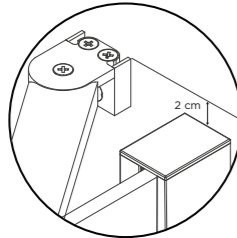

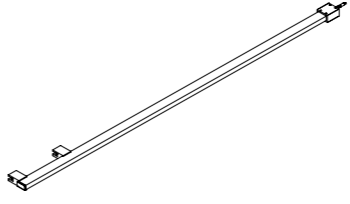
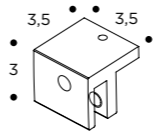
	80	85	90	95	100	105	110	115	120
80	45					49			
85									
90									
95									
100									
105	49					52			
110									
115									
120									

DISEGNO DRAWING DESSIN	DESCRIZIONE DESCRIPTION DESCRIPTION	FINITURA FINISH FINITION	ART. ITEM ART.
	BRACCETTO MURO-VETRO L 119 CM STABILIZING BAR WALL-PANEL W. 119 CM BARRE DE STABILIZATION MUR-PAROI L 119 CM	BRILL	D8XR005B
		NERO	D8XR005N
		SPECIAL	D8XR005*
	BRACCETTO MURO-VETRO L 159 CM STABILIZING BAR WALL-PANEL W. 159 CM BARRE DE STABILIZATION MUR-PAROI L 159 CM	BRILL	D8XR011B
		NERO	D8XR011N
		SPECIAL	D8XR011*
	BRACCETTO MURO-MURO L 199 CM STABILIZING BAR WALL-WALL W. 199 CM BARRE DE STABILIZATION MUR-MUR L 199 CM	BRILL	D8XR010B
		NERO	D8XR010N
		SPECIAL	D8XR010*
	BRACCETTO CORTO L 100 CM STABILIZING BAR REDUCED DIMENSION W. 100 CM BARRE DE STABILIZATION DIMENSION RÉDUITES L 100 CM	BRILL	D8XR007B
		NERO	D8XR007N
		SPECIAL	D8XR007*
	BRACCETTO 45° L 33 CM STABILIZING BAR FOR 45° APPLICATION (W. 33 CM) BARRE DE STABILIZATION POUR APPLICATION À 45° (L 33 CM)	BRILL	D8XR004B
		NERO	D8XR004N
		SPECIAL	D8XR004*
	BRACCETTO 45° L 43 CM STABILIZING BAR FOR 45° APPLICATION (W. 43 CM) BARRE DE STABILIZATION POUR APPLICATION À 45° (L 43 CM)	BRILL	D8XR009B
		NERO	D8XR009N
		SPECIAL	D8XR009*

DISEGNO DRAWING DESSIN	DESCRIZIONE DESCRIPTION DESCRIPTION	FINITURA FINISH FINITION	ART. ITEM ART.
	BRACCETTO SOFFITTO L 120 CM CEILING-MOUNTED STABILIZING BAR (W. 120 CM) BARRE DE STABILIZATION À PLAFOND (L 120 CM)	BRILL	D8XR025B
		NERO	D8XR025N
		SPECIAL	D8XR025*
	PINZA MURO-VETRO PINCE WALL-PANEL PINCE MUR-PAROI	BRILL	D8XR026B
		NERO	D8XR026N
		SPECIAL	D8XR026*
	GUARNIZIONE INFERIORE BATTENTE HINGED DOOR BOTTOM GASKET JOINT INFÉRIEUR POUR PORTE BATTANTE		DGMA0100
	GUARNIZIONE INFERIORE SCORREVOLE SLIDING DOOR BOTTOM GASKET JOINT INFÉRIEUR POUR PORTE COULISSANTE		DGMA0110
	GUARNIZIONE VERTICALE BATTENTE HINGED DOOR VERTICAL GASKET JOINT VERTICAL POUR PORTE BATTANTE		DGMA0130
	GUARNIZIONE VERTICALE SCORREVOLE SLIDING DOOR VERTICAL GASKET JOINT VERTICAL POUR PORTE COULISSANTE		DGMA0120