

SIPARIO

ISTRUZIONI
DI MONTAGGIO
BOX DOCCIA



SHOWER ENCLOSURES
ASSEMBLY
INSTRUCTIONS

CABINE DE DOUCHE
INSTRUCTIONS
MONTAGE

INDICE | CONTENTS | SOMMAIRE

INFORMAZIONI GENERALI

GENERAL INFORMATION | INFORMATIONS GÉNÉRALES

P. 3-5

ISTRUZIONI DI MONTAGGIO

ASSEMBLY INSTRUCTIONS | INSTRUCTIONS MONTAGE

- **Angolo - Walk-in con prolunga**

Corner - Walk-in with extension

Coin - Walk-in avec extension

P. 6-15

INFORMAZIONI GENERALI

Prima di installare e utilizzare il box doccia si prega di leggere attentamente le istruzioni di montaggio e di conservarle per successive consultazioni. L'azienda non si assume alcun tipo di responsabilità per box doccia non montati alla perfezione da personale specializzato.

Prima di installare il box doccia è necessario o assicurarsi che:

- > Il contenuto dell'imballo sia conforme a quanto ordinato;
- > Il prodotto consegnato non abbia subito danni durante il trasporto e non sia danneggiato;
- > L'impianto idraulico rispetti le norme vigenti in materia;
- > Le linee elettriche o del gas non coincidano con i punti di fissaggio;
- > La predisposizione idraulica sia conforme alla tipologia di prodotto da installare;
- > Lo scarico sia funzionante ed efficiente;
- > Il piatto doccia sia stato installato in modo corretto;
- > L'installazione venga effettuata da personale specializzato e qualificato;

I tasselli e le viti incluse nel kit di montaggio sono da utilizzare per pareti in laterizio e intonaco. In caso di altri tipi di supporto, utilizzare sistemi di fissaggio specifici. Il produttore si riserva il diritto di apportare modifiche al prodotto senza preavviso.

PULIZIA

Il primo consiglio per mantenere un box doccia pulito è quello di utilizzare un tergivetro dopo ogni utilizzo, per asciugare la superficie del vetro. Questa veloce pratica quotidiana consentirà di risparmiare tempo nella pulizia periodica, in quanto la formazione di calcare sarà molto ridotta. Il calcare è una incrostazione costituita da carbonato di calcio: tali depositi, se controllati attraverso una manutenzione periodica, non devono preoccupare e non influiscono in nessun modo sul buon funzionamento dei prodotti Ibra Showers. Per pulire i vetri delle nostre cabine doccia consigliamo l'utilizzo di una soluzione al 50% di aceto e acqua tiepida, spruzzando il prodotto sulle pareti e successivamente risciacquando tamponando con un panno morbido.

VETRI CON TRATTAMENTO ANTICALCARE

Se sul vetro è stato applicato il trattamento anticalcare, si consiglia di pulire quotidianamente, dopo l'utilizzo della doccia, con un panno leggermente bagnato per rimuovere eventuali residui e successivamente utilizzare un tergivetro. Per non danneggiare il trattamento si raccomanda di non utilizzare prodotti abrasivi, in pasta o polvere, alcool, candeggina, detergenti aggressivi, prodotti anticalcare e panni in microfibra.

VETRI SABBIA TI

Protettivo antimacchia

I vetri sabbia ti sono trattati con un prodotto contenente un gel silice nano-strutturata che una volta steso funge da filler e impedisce la penetrazione di sporco e impurità nelle microporosità e nelle fessurazioni create dal processo di sabbiatura.

Resistenza ai detergenti e manutenzione

Per la pulizia delle superfici trattate è sufficiente l'utilizzo di acqua e detergenti neutri servendosi di spugne morbide o di panni in microfibra. Evitare alcool puri, detergenti in polvere, sostanze fortemente alcaline e prodotti abrasivi.

Ripristino

In trattamento può essere ripristinato con lo stesso prodotto disponibile come kit.

COMPONENTI (SISTEMI DI SCORRIMENTO, CERNIERE, ETC.)

Le componenti meccaniche, se non utilizzate per molto tempo, possono richiedere periodicamente di essere oliate o verificate da personale qualificato per garantire un ottimale funzionamento.

GUARNIZIONI

Le guarnizioni sono per natura soggette a un invecchiamento estetico e funzionale. Ibra Showers utilizza solo guarnizioni di alta qualità, progettate per un ciclo di vita il più lungo possibile, tuttavia la loro sostituzione periodica è inevitabile. Questa fase di manutenzione è, però, economica e facilmente eseguibile anche da un utente non esperto.

RITENZIONE ALL'ACQUA

I prodotti Ibra Showers rispondono alla normativa UNI EN 14428, la quale cita che, spruzzando dell'acqua con i dovuti criteri e comunque mai direttamente su profilo di contenimento e guarnizioni, c'è una minima tolleranza di fuoriuscita di gocce d'acqua all'esterno. Ibra Showers progetta e produce prodotti con caratteristiche superiori al minimo richiesto dalla normativa, ma ricordiamo che un utilizzo improprio della doccia non garantisce le medesime caratteristiche.

GENERAL INFORMATION

Before installing and using the shower enclosure, please read the assembly instructions carefully and store them for future consultation. The company assumes no responsibility for shower enclosures that have not been perfectly fitted by a specialist.

Before installing the shower enclosure, make sure that:

- > The contents of the package correspond to the order;
- > The delivered item has not been damaged during the transportation or is defected;
- > The plumbing complies with the current regulations;
- > Gas pipe or electric cables do not coincide with the installation points;
- > The plumbing fittings are compliant with the type of product to be installed;
- > The drain is working well;
- > The shower tray has been correctly installed;
- > Installation is carried out by a qualified specialist;

The plates and screws included in the assembly kit are to be used for brick and plaster walls. In case of other types of support, use specific fixing systems. The manufacturer reserves the right to make changes to the product without prior notice.

CLEANING

The first piece of advice for keeping a shower enclosure clean is to pass over surfaces with a squeegee after every use, to dry the glass. This quick daily step will save you time on periodic cleaning, as there will be far less limescale build-up. Limescale is the accumulation of calcium carbonate. This deposit, if kept under control by regular maintenance, should not be a problem and should not have any impact on the proper functioning of Ibra Showers products. To clean the glazing of our shower enclosures, we recommend using a 50% vinegar and warm-water solution. Spray it onto surfaces and then rinse, padding with a soft cloth.

GLAZING WITH ANTI-LIMESCALE TREATMENT

If the glazing has an anti-limescale treatment, we recommend cleaning daily, after each shower, with a slightly damp cloth. Once any residues have been removed a squeegee should be passed over the surfaces. To avoid damaging the treatment, do not use abrasive products, powders or pastes, alcohols, bleach, aggressive detergents, anti-limescale products or microfibre cloths.

FROSTED GLASS

Anti-marking protective treatment

Frosted glass is treated with a product containing a nano-structured silica gel. Once applied, this acts as a filler and prevents the penetration of dirt and impurities into the micropores and channels created by the sand-blasting process.

Resistance to detergents and maintenance

To clean treated surfaces, simply use water and neutral detergents with a soft sponge or microfibre cloth. Avoid using pure alcohols, powdered detergents, strongly alkaline substances and abrasive products.

Renewal

The treatment can be renewed using the same product available as a kit.

COMPONENTS (SLIDING SYSTEMS, HINGES, ETC.)

Mechanical components, if left unused for long periods, may require periodic oiling or checks by qualified personnel to ensure they work properly.

SEALS

Seals are exposed to aesthetic and functional ageing by their very nature. Ibra Showers only uses high-quality seals, designed for the longest possible life cycle. However, periodic replacement is inevitable. However, this maintenance step is inexpensive and easily performed even by untrained users.

WATER RETENTION

Ibra Showers products meet the requirements of standard UNI EN 14428, which states that when water is sprayed in line with specific criteria, and never directly on the containment profile and seals, there is minimal leakage of water droplets outside the shower enclosure. Ibra Showers designs and manufactures products with specifications beyond the minimum requirements required by the standard, nevertheless, improper use of the shower may compromise these specifications.

INFORMATIONS GÉNÉRALES

Avant d'installer et d'utiliser les parois de douche, veuillez lire attentivement les instructions de montage et le conserver pour des consultations ultérieures. L'entreprise n'assume aucune responsabilité pour les parois de douche ou les carreaux non montés à la perfection par du personnel spécialisé.

Avant d'installer le receveur de douche, il convient de s'assurer que:

- > Le contenu de l'emballage est conforme à la commande;
- > Le produit livré n'est pas cassé et il ne présente pas d'autres défauts;
- > Le système hydraulique respecte les normes en vigueur en la matière;
- > Les câblages électriques ou les tuyaux du gaz ne se trouvent pas en corrépondance des point de fixation;
- > L'emplacement hydraulique est conforme au type de produit à installer;
- > Le déchargement est fonctionnel et efficace;
- > Le bac à douche n'a pas été installé correctement;
- > L'installation a été effectuée par du personnel spécialisé et qualifié;

Les chevilles et les vis incluses dans le kit de montage doivent être utilisées pour les murs en brique et en plâtre. Dans le cas d'autres types de support, utilisez des systèmes de fixation spécifiques. Le fabricant se réserve le droit d'apporter des modifications au produit sans préavis.

NETTOYAGE

Le premier conseil pour maintenir une cabine de douche propre est d'utiliser une raclette pour vitre après chaque utilisation, pour essuyer la surface en verre. Cette pratique quotidienne et rapide permettra de gagner du temps lors du nettoyage périodique, car la formation de calcaire sera fortement réduite. Le calcaire est une incrustation constituée de carbonate de calcium : ces dépôts, si contrôlés avec un entretien périodique, ne sont pas préoccupants et n'influencent en aucune manière le bon fonctionnement des produits Ibra Showers. Pour nettoyer les vitres de nos cabines de douche, nous recommandons d'utiliser une solution à 50% de vinaigre et d'eau tiède, de vaporiser le produit sur les parois, puis de rincer en tamponnant à l'aide d'un chiffon doux.

VERRE AVEC TRAITEMENT ANTI-CALCAIRE

Si un traitement anti-calcaire a été appliqué sur le verre, il est recommandé de le nettoyer quotidiennement, après la douche, à l'aide d'un chiffon légèrement humide pour éliminer les éventuels résidus, puis d'utiliser une raclette pour vitre. Pour ne pas endommager le traitement, il est recommandé de ne pas utiliser de produits abrasifs, en pâte ou en poudre, d'alcool, d'eau de javel, de détergents agressifs, de produits anti-calcaire et de chiffons en microfibre.

VERRE SABLÉ

Protection antitache

Le verre sablé est traité avec un produit contenant un gel de silice nanostructuré qui, une fois étalé, agit comme un agent de remplissage et empêche la pénétration de saletés et d'impuretés dans les microporosités et fissures créées par le processus de sablage.

Résistance aux détergents et entretien

Pour nettoyer les surfaces traitées, il suffit d'utiliser de l'eau et des détergents neutres à l'aide d'éponges douces ou de chiffons en microfibre. Éviter l'alcool pur, les détergents en poudre, les substances hautement alcalines et les produits abrasifs.

Remise en état

Lors du traitement, il peut être remis en état avec le même produit disponible en kit.

COMPOSANTS (SYSTÈMES DE COULISSEMENT, CHARNIÈRES, ETC.)

Les composants mécaniques, si non utilisés pendant une longue période, peuvent nécessiter périodiquement d'être huilés ou contrôlés par un personnel qualifié pour garantir un fonctionnement optimal.

JOINTS

Les joints sont par nature sujets au vieillissement esthétique et fonctionnel. Ibra Showers utilise uniquement des joints de haute qualité, conçus pour le cycle de vie le plus long possible, mais leur remplacement périodique est inévitable. Cette phase d'entretien est cependant économique et facilement réalisable même par un utilisateur non expert.

RÉTENTION D'EAU

Les produits Ibra Showers sont conformes à la norme UNI EN 14428, qui stipule qu'en pulvérisant de l'eau avec les critères nécessaires et en aucun cas directement sur le profil de confinement et les joints, il existe une tolérance minimale pour que des gouttes d'eau s'échappent à l'extérieur. Ibra Showers conçoit et fabrique des produits aux caractéristiques supérieures au minimum requis par la norme, mais nous rappelons qu'une mauvaise utilisation de la douche ne garantit pas les mêmes caractéristiques.

UTENSILI PER IL MONTAGGIO ASSEMBLY TOOLS | OUTILS DE MONTAGE

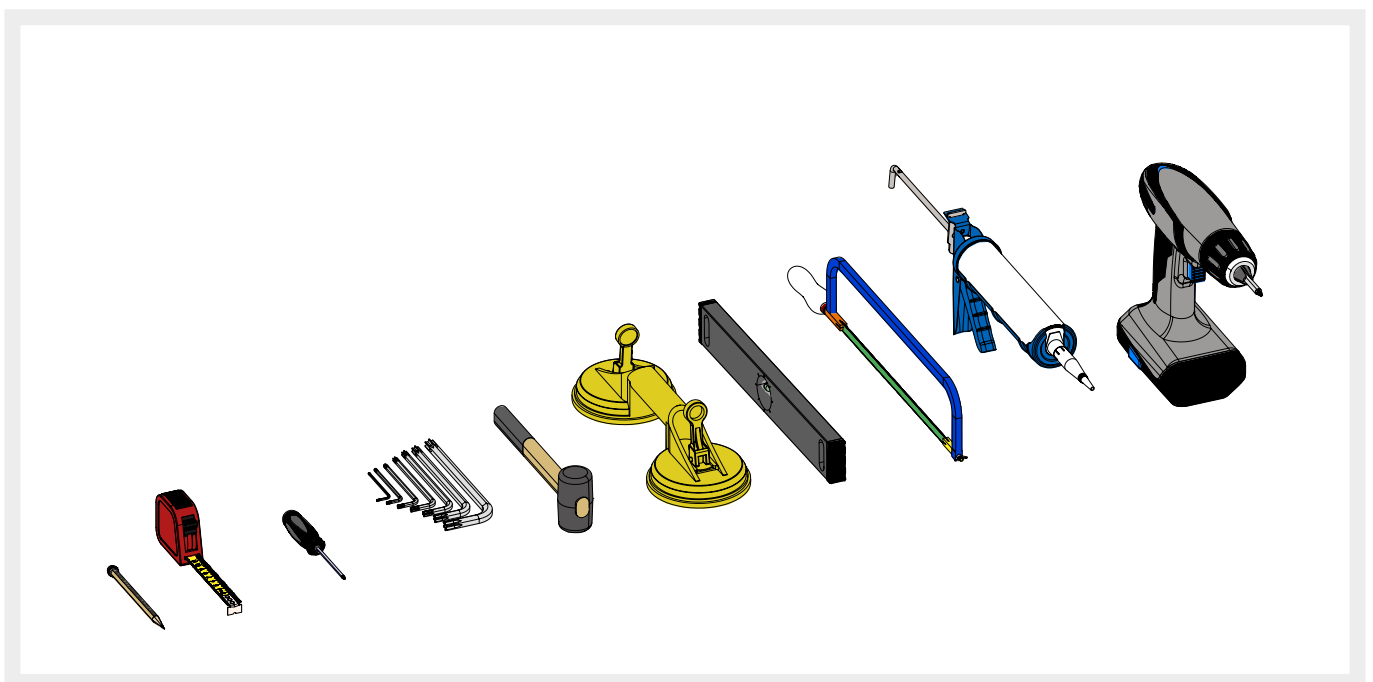

ISTRUZIONI DI MONTAGGIO ASSEMBLY INSTRUCTIONS INSTRUCTIONS MONTAGE



DISA001

KIT 6/8 mm	Codice Code Code	Quantità Quantity Quantité
	DFTC065	2
	DFTC066	2
	DFAS007	1
	DFAS008	1
	DFGI07A	1
	DFGI005	1
	DFTC07L	1

KIT 6/8 mm	Codice Code Code	Quantità Quantity Quantité
x 2 	DFVI114	1
x 4  M3X14TCEI		
	DFVI107	1
	DFTC061	1
	DFTC076	1
	DISA001	1

I tasselli e le viti incluse nel kit di montaggio sono da utilizzare per pareti in laterizio e intonaco. In caso di altri tipi di supporto, utilizzare sistemi di fissaggio specifici. Il produttore si riserva il diritto di apportare modifiche al prodotto senza preavviso.

The plugs and screws included in the mounting kit are for use on brick and plaster walls. For other types of surfaces, use specific fastening systems. The manufacturer reserves the right to make changes to the product without prior notice.

Les chevilles et les vis fournies dans le kit de montage doivent être utilisées pour les murs en briques et en plâtre. Pour les autres types de supports, utilisez des systèmes de fixation spécifiques. Le fabricant se réserve le droit d'apporter des modifications au produit sans préavis.

MISURE UTILI PER L'INSTALLAZIONE USEFUL MEASURES FOR INSTALLATION MESURES UTILES POUR L'INSTALLATION

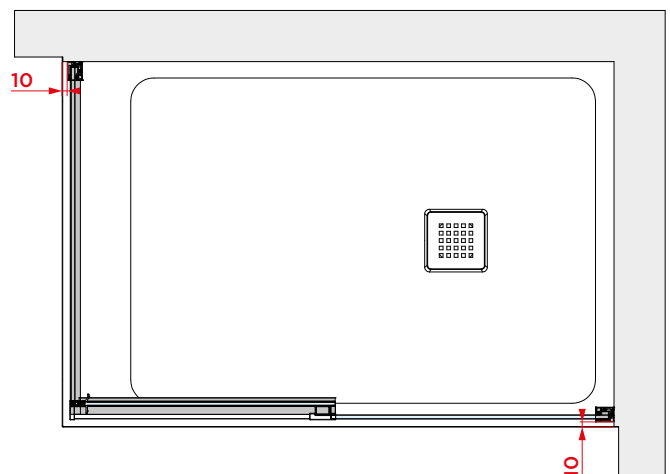

1

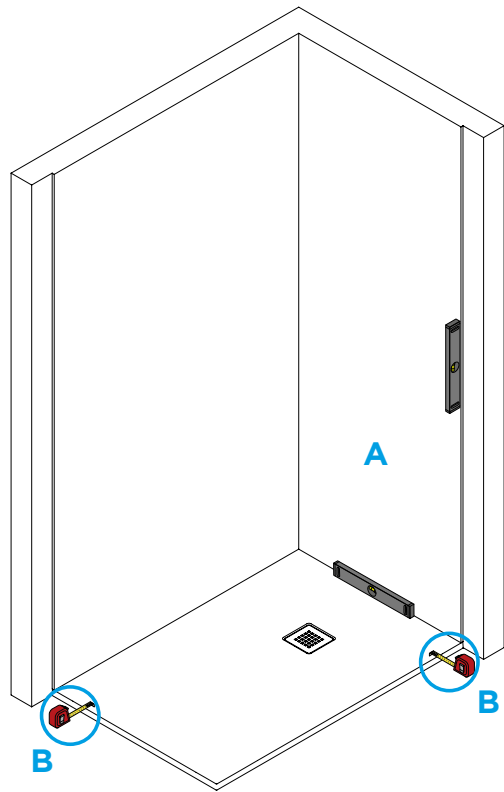
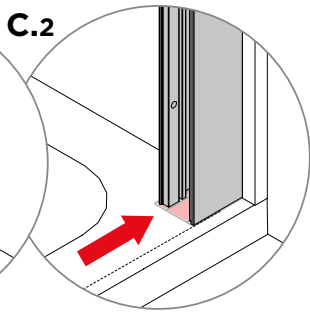
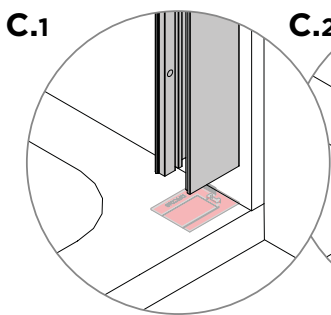
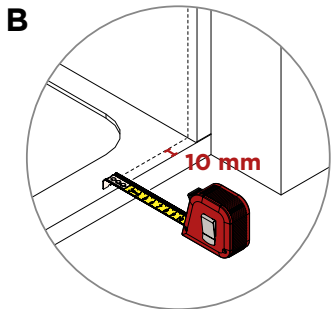
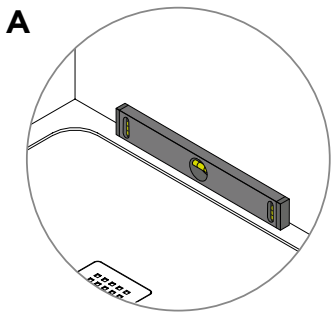

2

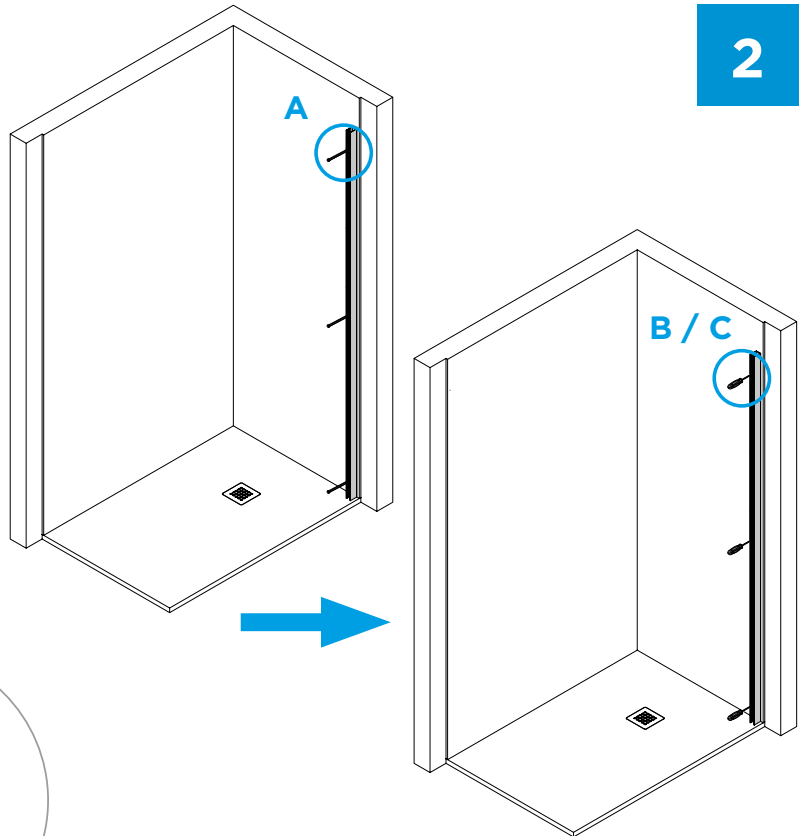
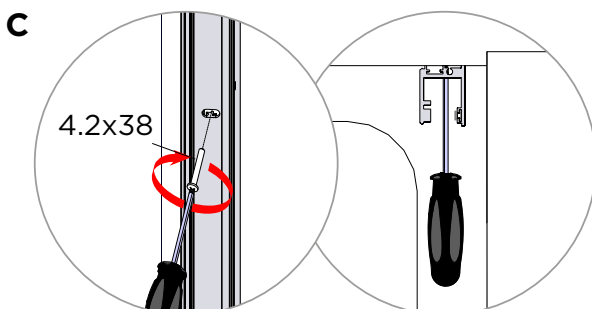
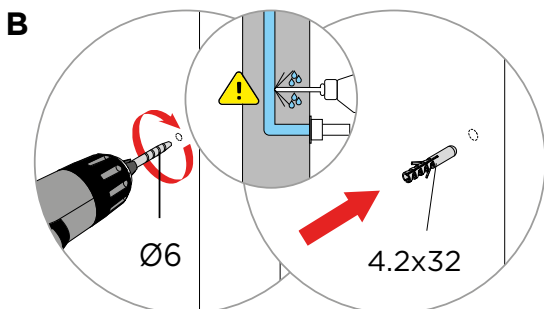
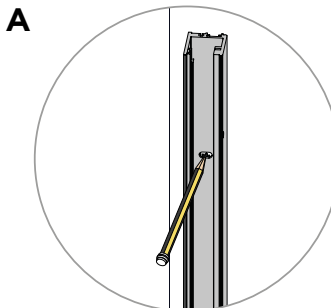

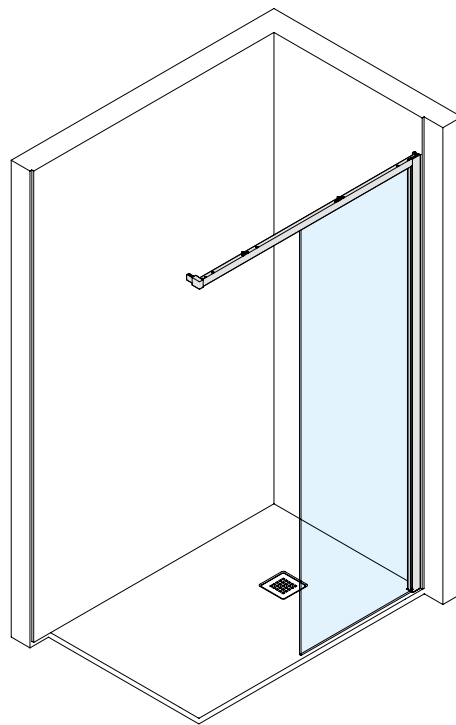
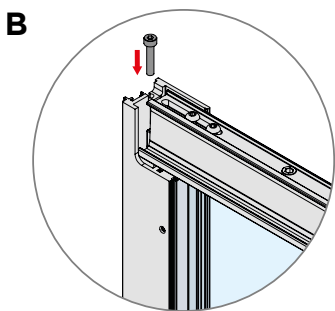
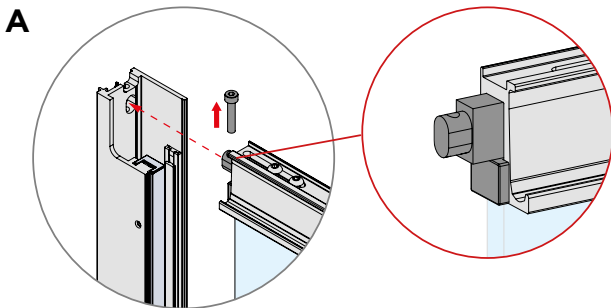
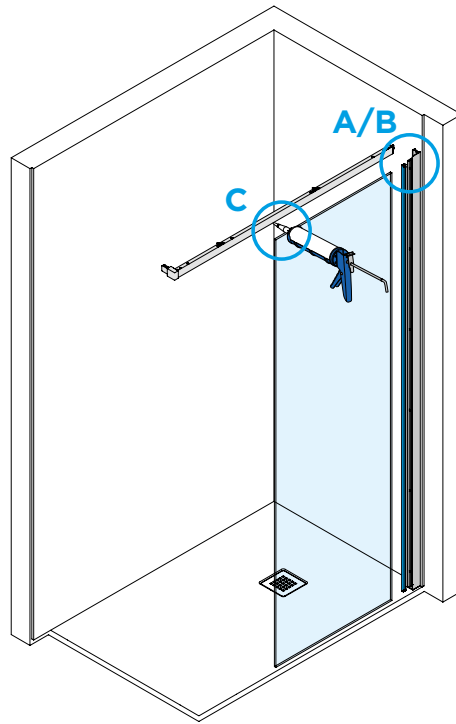
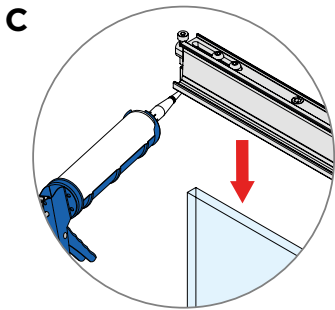
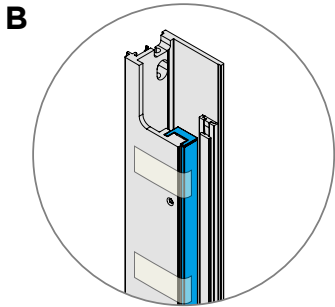
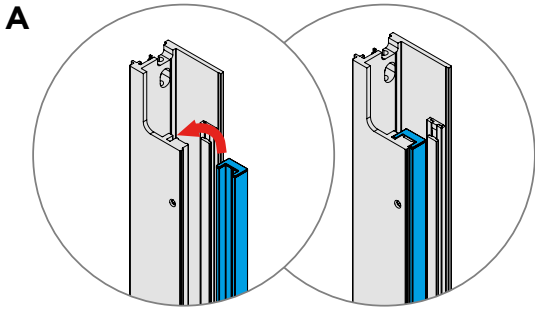

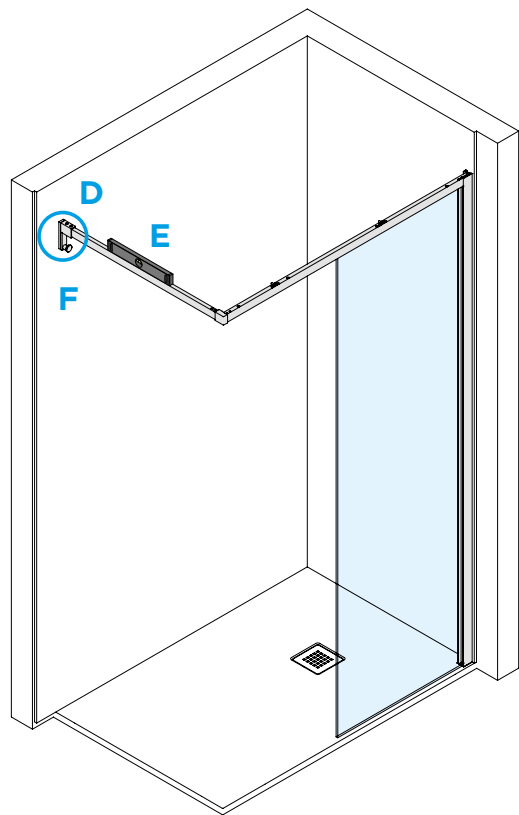
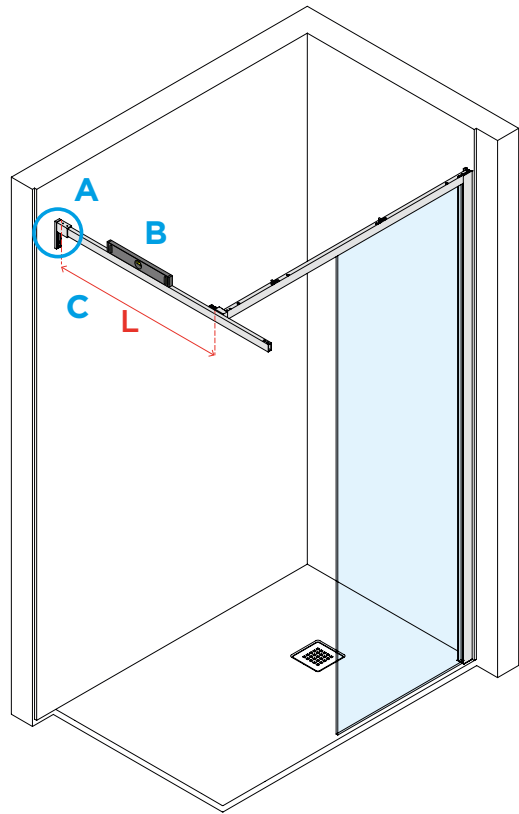
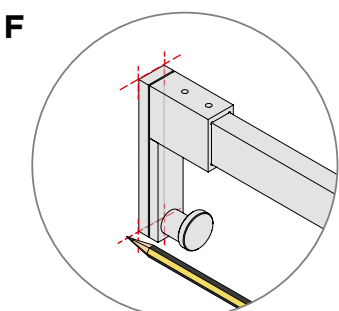
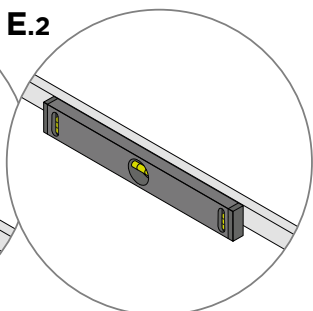
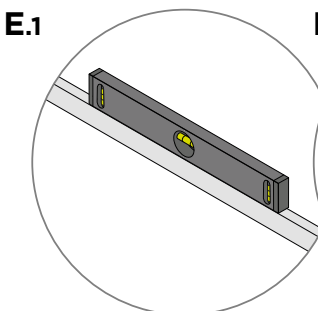
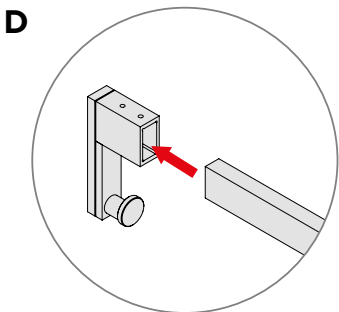
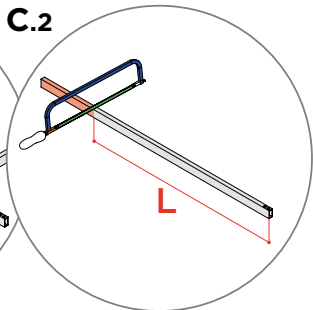
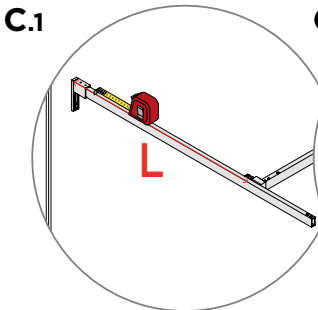
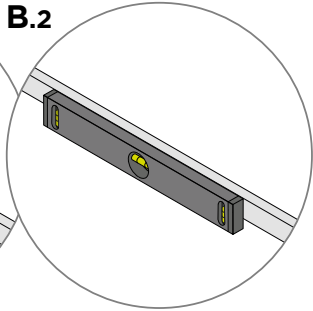
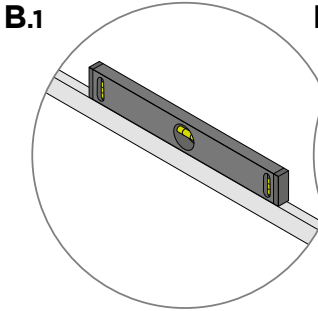
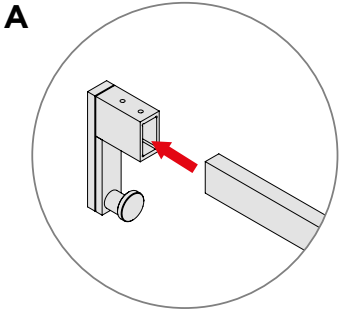

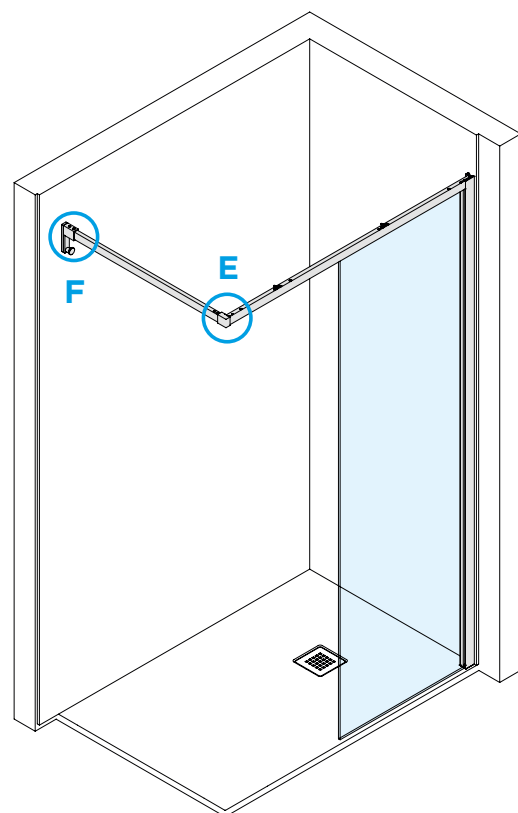
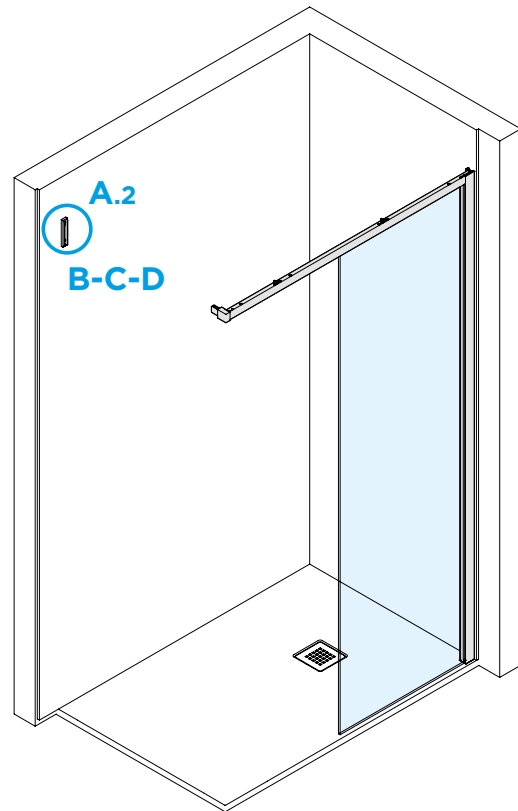
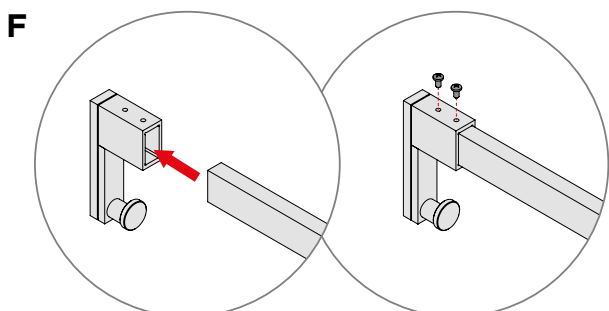
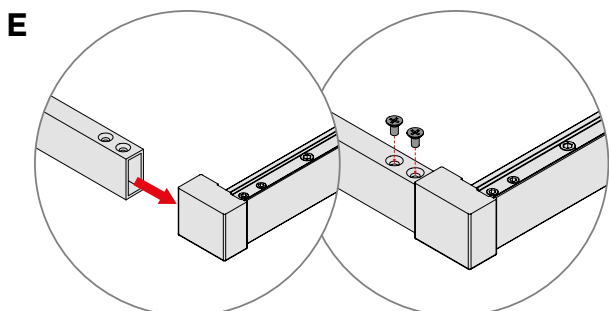
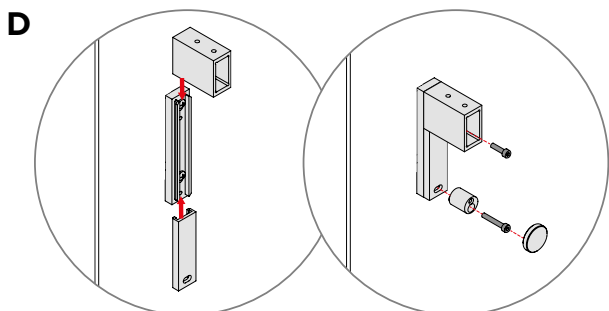
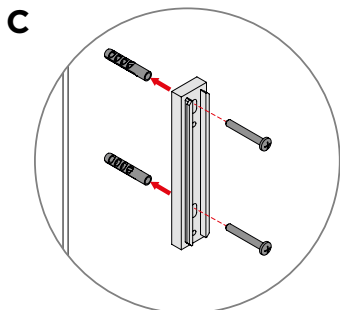
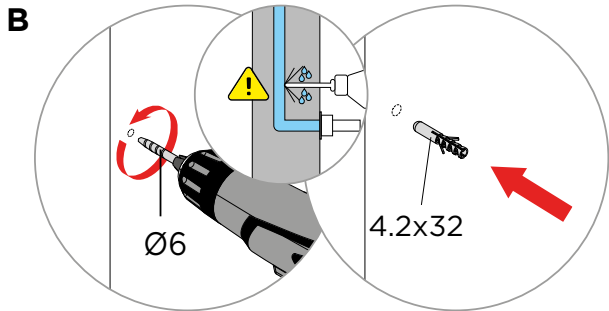
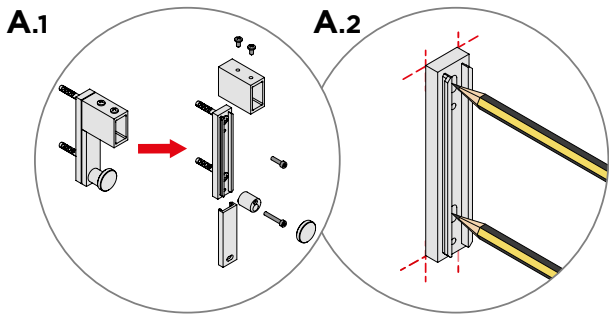

7

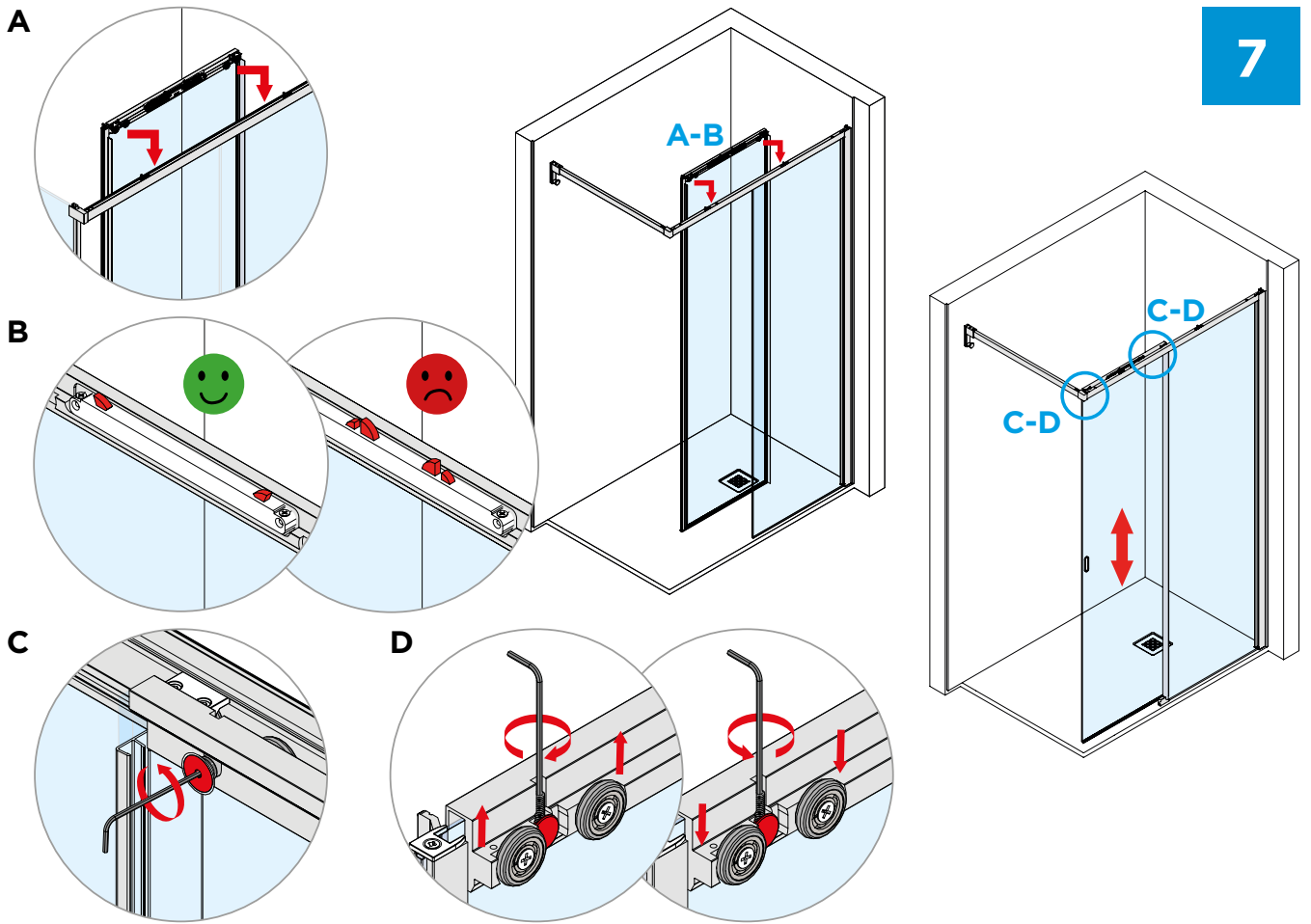

8

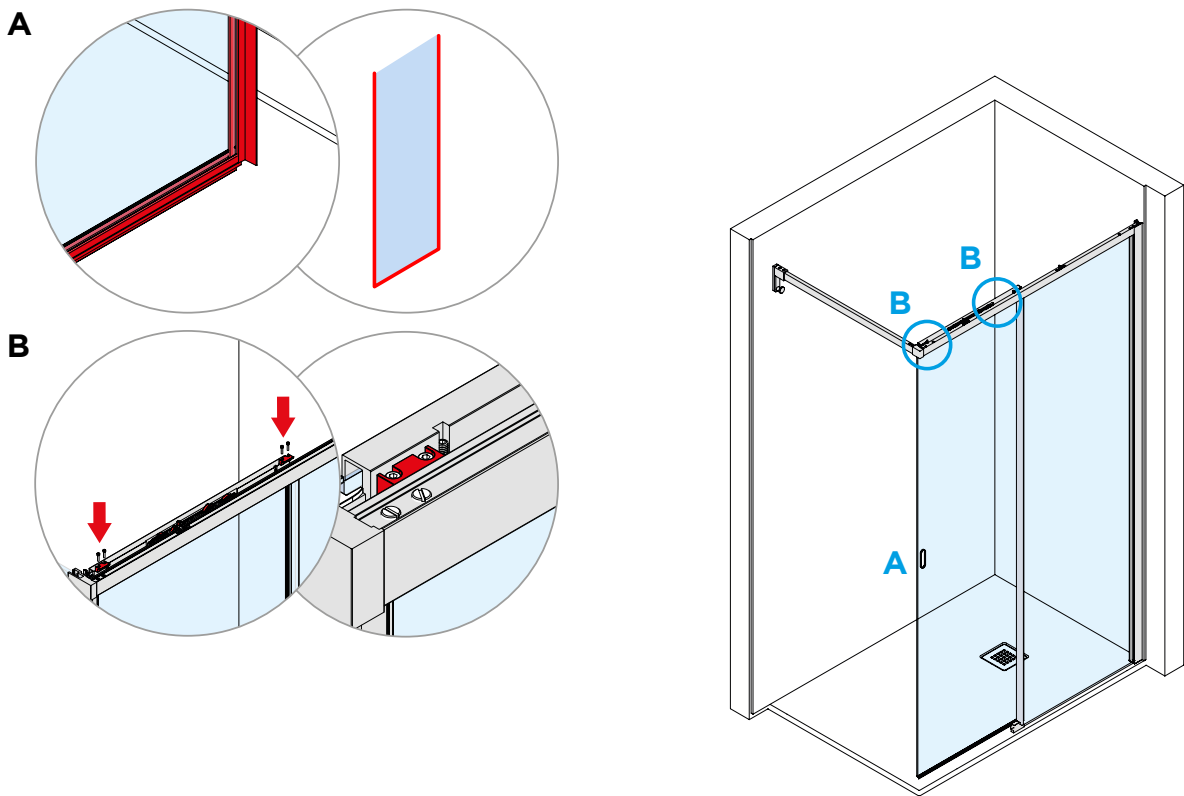

OPTION 1

SENZA BARRIERA
BARRIER-FREE
SANS BARRIÈRE

9

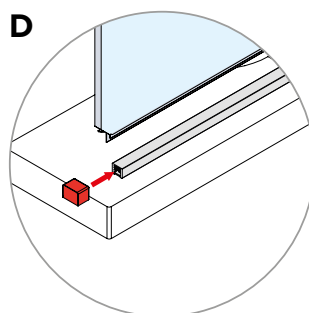
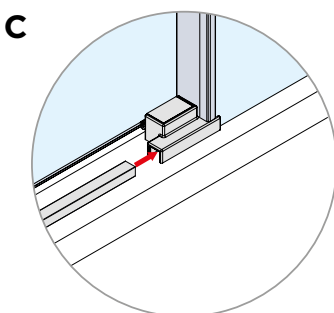
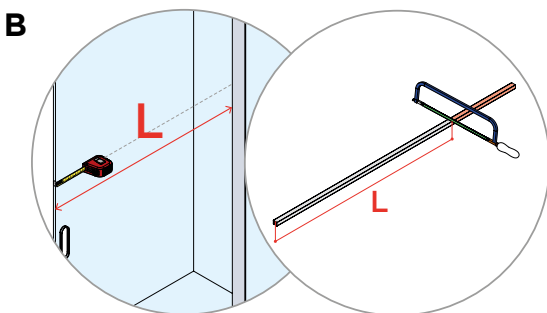
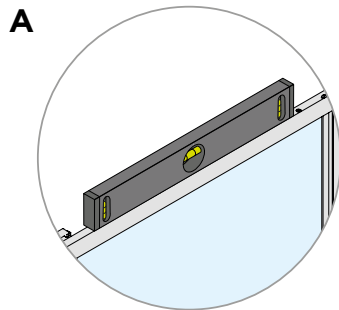
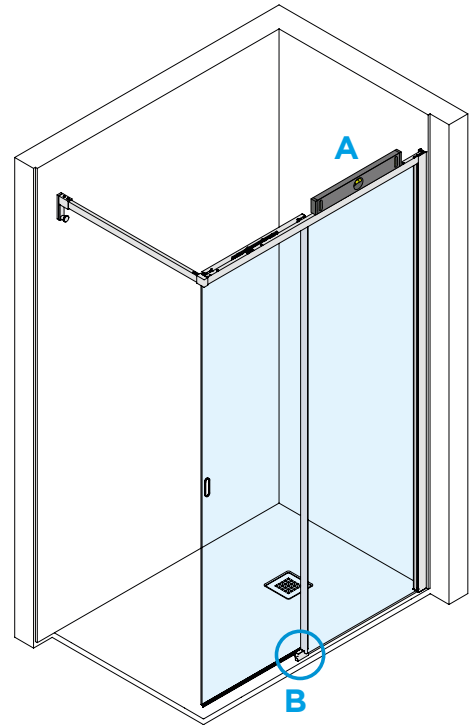
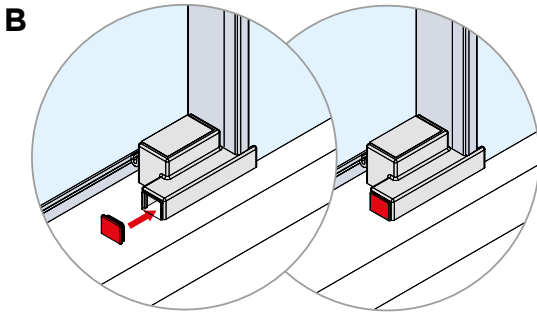
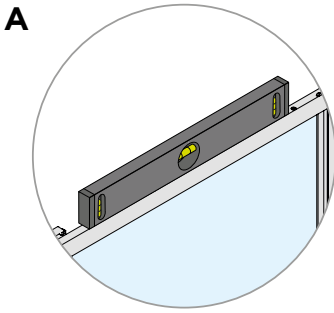

OPTION 2

BARRIERA LATO PORTA
DOOR SIDE BARRIER
BARRIÈRE DU CÔTÉ PORTE

9

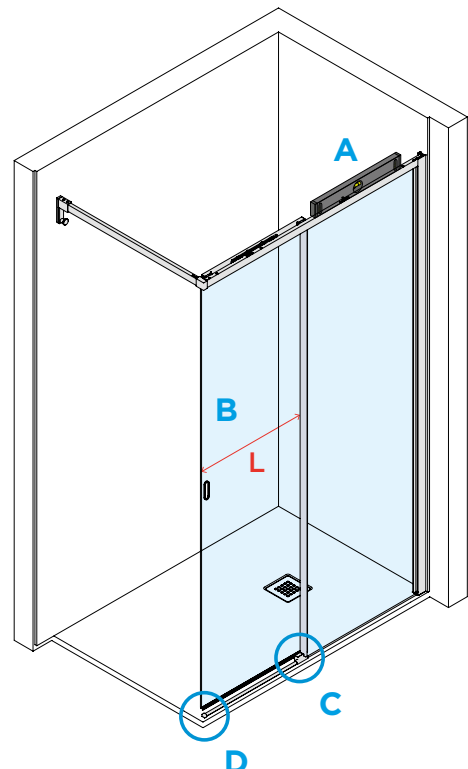

OPTION 3

BARRIERA COMPLETA
FULL BARRIER
BARRIÈRE COMPLÈTE

9

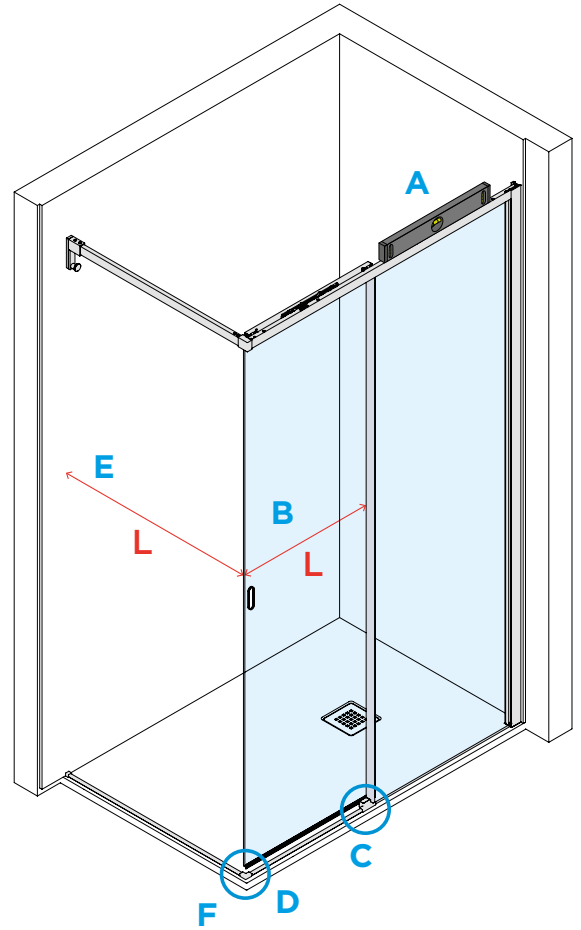
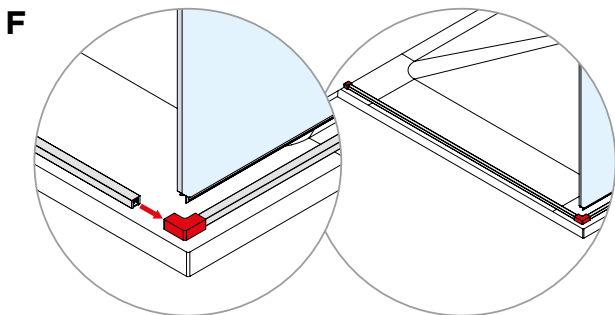
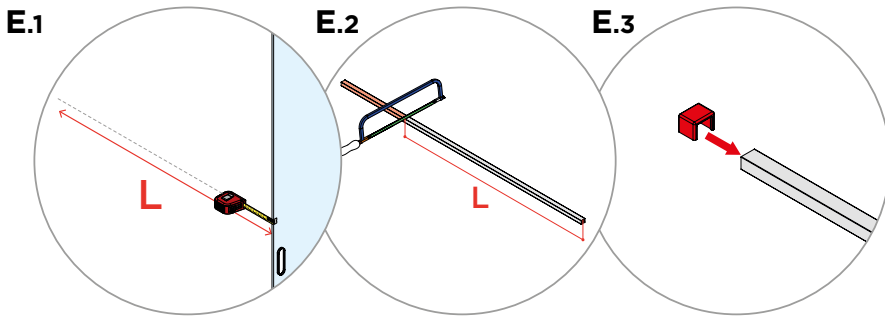
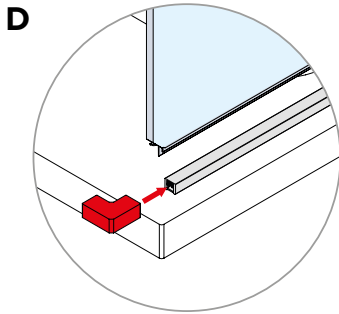
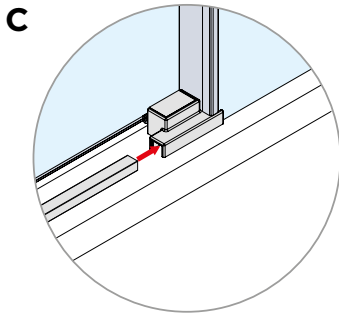
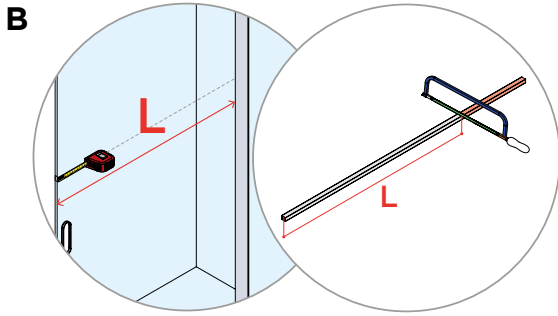
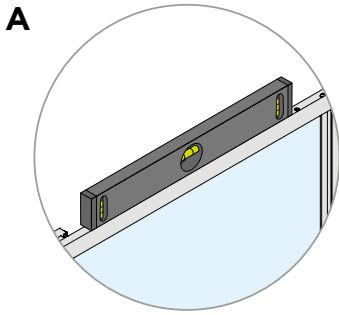

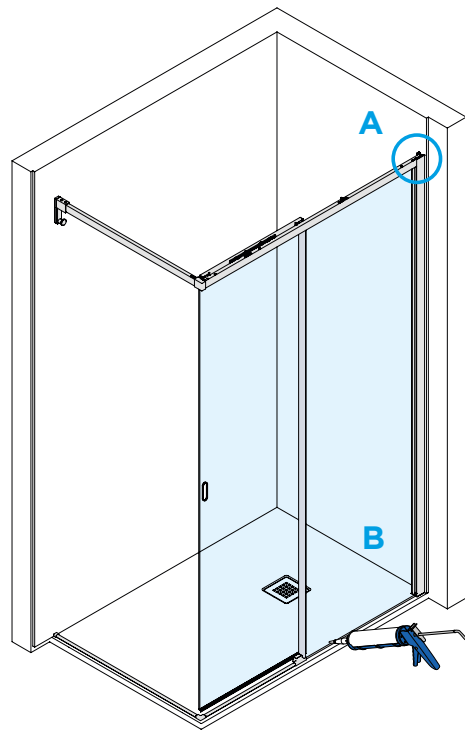
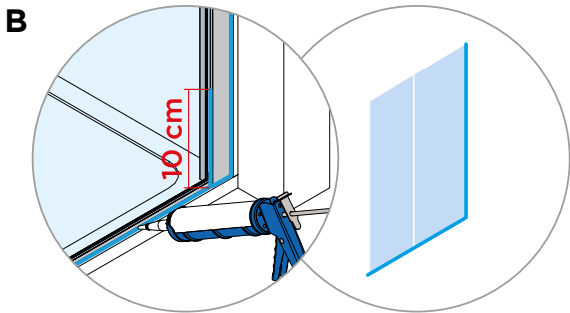
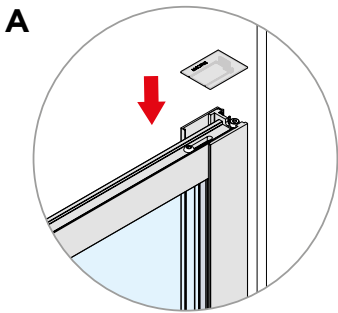
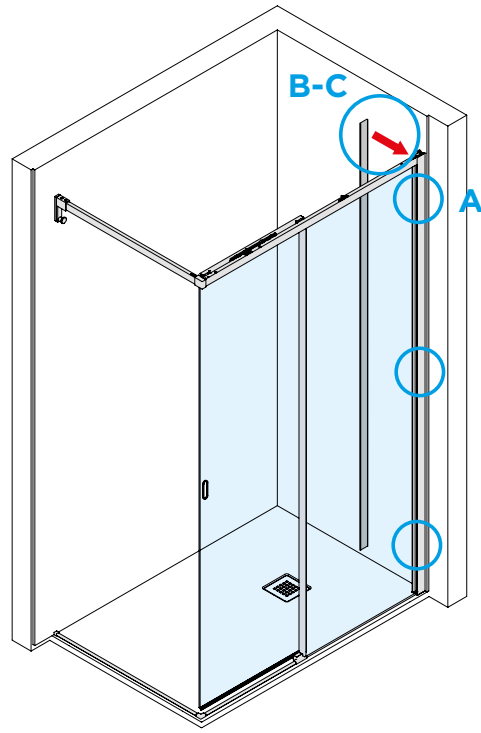
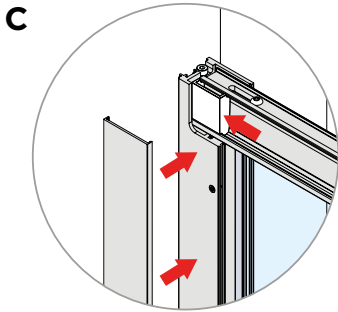
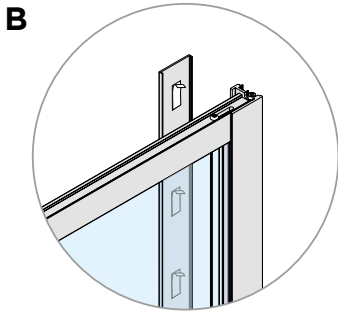
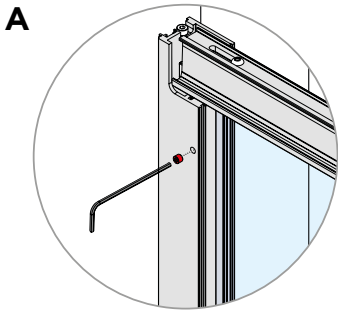



Viale Lino Zanussi, 34/A
33070, Maron di Brugnera
Pordenone - Italy
T. +39 0434 624822

info@ibradocce.it
www.ibrashowers.it